

# Oil, Gas and Dual Fuel Burners

Burner series 300...700

Group

**4**

Capacity  
770-9700 kW





## Table of contents

General	1
How to choose a burner	2
<b>Light oil burners</b>	
Technical data and dimensions	3
PI-diagrams	4
Scope of delivery	4
Capacity/back pressure graphs	5
<b>Heavy oil burners</b>	
Technical data and dimensions	6
PI-diagrams	7
Scope of delivery	7
Capacity/back pressure graphs	8
<b>Gas burners</b>	
Technical data and dimensions	9
PI-diagrams	10
Scope of delivery	11
Capacity/back pressure graphs	12
<b>Dual fuel burners, light fuel oil/gas</b>	
Technical data and dimensions	13
PI-diagrams	14
Scope of delivery	15
Capacity/back pressure graphs	16
<b>Dual fuel burners, heavy fuel oil/gas</b>	
Technical data and dimensions	17
PI-diagram	18
Scope of delivery	19
Capacity/back pressure graphs	20
Gas valve selection table	21
Gas elbow	22
Low NOx gas burner	22
Control panels and supply cabinets	23
WiseDrive – an electronic regulator for controlling the fuel/air ratio	24
Burner preheater	25
Silencer	25
Optimising combustion head pressure loss	26
Masonry figure	26
Flame dimensions	26
Oil supply diagram for heavy fuel oil	27
Gas pressure control assembly	27



Light oil burners

3 - 5



Heavy oil burners

6 - 8



Gas burners

9 - 12



Dual fuel burners, light fuel oil/gas

13 - 16



Dual fuel burners, heavy fuel oil/gas

17 - 20



# Oil, Gas and Dual Fuel Burners

Burner series 300...700



Oilon oil, gas, and dual fuel burners are fully automatic, safe, and reliable. The design and manufacturing of the burners is based on economy, safety, and service as well as environmental friendliness. Our gas burners comply with the EN 676 standard, oil burners with the EN 230 and EN 267 standards, and dual fuel burners with all of these standards. All burners are EU type tested. We also supply burners complying with various marine classification society requirements, such as ABS, BV, CCS, DNV, GL, KR, LR, NKK, RINA, and RS.

## Construction

The steel plate housing incorporates a three-phase motor that runs the fan located in the housing. The oil pump has its own three-phase motor. The surface of the housing is finished with durable high-gloss paint. The housing is equipped with a hinged burner flange with a safety interlock switch, enabling the burner to be swung open to the left or right. The burner flange enables servicing of the combustion head, nozzles, and ignition electrodes without having to remove the burner itself. The stainless steel alloy combustion head and the diffuser disc can withstand temperatures up to 1,200 °C. The combustion head is adjustable, to optimise the mixing of fuel regardless of the firing rate. The burner houses a sight glass for flame observation. On the fan suction side there is an air damper that, together with the servomotor, automatically controls the amount of fuel and air based on demanded firing rate. A removable top cover allows ease of electrical installations and burner service.

## Installation and suitable applications

The burners are suitable for warm and hot water boilers, steam boilers, hot air generators, and various types of process heating. They are also designed to suit furnaces with high back pressure. The burners can be mounted in horizontal, vertical and upward-facing, or vertical and downward-facing orientation. Our burners are designed for operation in covered areas, max. +50 °C. Normal operation altitude is 500 metres above sea level (other altitudes upon request). The burner enclosure class of the burner is IP 20.

## Fuels

Different fuels can be used depending on the burner model:

KP models:

- light fuel oil, viscosity 4 to 12 mm<sup>2</sup>/s, +20 °C

RP models:

- heavy fuel oil, viscosity max. 250 mm<sup>2</sup>/s, +50 °C
- heavy fuel oil, viscosity max. 450 mm<sup>2</sup>/s, +50 °C heating cartridge for pump, nozzle and solenoid valves
- heavy fuel oil, viscosity max. 650 mm<sup>2</sup>/s, +50 °C heating cartridges as above + trace heating for the oil piping

GP models:

- natural gas, 2<sup>nd</sup> family gases, groups H and E (equipment category 1<sub>2R</sub>)

GKP and GRP dual fuel burners:

- fuel properties as above, natural gas/light fuel oil
- fuel properties as above, natural gas/heavy fuel oil

Burners using other fuels are available upon request.

Gas and dual fuel burners meet the low NO<sub>x</sub> class requirements (EN 676 and EN267) in gas burning.

## Capacity regulation method

Modulating burners are equipped with a servomotor with a run time of 30 sec./90°. The servomotor is connected to the oil regulator and compound regulator via an axle. A modulating burner operates regardless of the firing rate, on the basis of the load. The burners are adjusted on the basis of combustion gas analysis.

## Oilon preheater guarantees accurate oil temperature control

RP and GRP models are equipped with oil shut-off valves and a filter, and an electric mass preheater. The preheater is controlled via an electronic regulator that keeps the oil temperature stable. A stable oil temperature makes it easier to obtain optimal combustion conditions. For our heavy oil burners, oil heated during the pre-burge phase flows to the nozzle through the preheater to ensure that the oil temperature is high enough during the ignition phase.

## Gas equipment

Gas-related components of the gas and dual fuel burners comply the standard EN 676: two shut-off valves, pressure switches (min./max.), and an automatic valve leak tester. Other piping-related equipment is available upon request.

## Oil piping

Mounted on the burner, three-stage burners with four solenoid valves (one main valve and one valve for each nozzle). Modulating burners have three solenoid valves. The oil regulator for the modulating burner is located on the nozzle return oil line. The oil filter is located on the suction side of the pump. The two oil hoses enable the burner to be hinged.

## Flame monitoring

All models are equipped with automatic flame monitoring. In KP and RP models, flame monitoring is taken care of via photocell; in GP, GKP, and GRP models, it is performed via UV cell.

## Control devices

The control automation (control unit) is located in a separate control panel. The control unit handles all burner operation phases automatically. In the event of a burner failure, the unit stops the burner automatically. The modulating burners also incorporate a pre-mounted capacity controller. Subject to additional charge, the burners can be delivered with electronic ratio control.

## Silencer

The sound level of the burners is low, but, if desired, they can be equipped with a separate silencer to make them even quieter.

## Optimising combustion head pressure loss

For an additional charge, the modulating burners can be equipped with a system that optimises the combustion head pressure loss. The system reduces the amount of excess air and also improves combustion figures for partial burner loads.

We reserve the right to make technical alterations.

# How to choose a burner

## A. Procedure

- Establish relevant boiler and application information
  - boiler capacity and efficiency, or required burner capacity
  - furnace back-pressure
  - fuel/fuels to be used
  - burner fuel inlet pressure
  - burner capacity regulation method
- Calculate the burner capacity. Burner capacity = boiler capacity/ efficiency  
 Example: boiler capacity of 6,500 kW, efficiency of 90 % → burner capacity = 6,500 kW / 0.9 = 7,220 kW.
- Gas burners: Required gas flow [m<sup>3</sup>/h] = (burner capacity [ kW ] x 3.6)/gas's calorific value [MJ/m<sup>3</sup>n]. Example: required burner capacity = 7,220 kW → required gas flow = (7,220 kW x 3.6)/35.8 MJ/m<sup>3</sup>n = 726 m<sup>3</sup>/h, where 35.8 MJ/m<sup>3</sup>n is the calorific value of natural gas.  
 Oil burners: Calculate the required oil flow [kg/h]. Required oil flow [kg/h] = (burner capacity [kW] x 3.6)/ the oil's calorific value [MJ/kg]. Example: required burner capacity = 7,220 kW → required oil flow = (7,220 kW x 3.6)/42.7 MJ/kg = 609 kg/h, where 42.7 MJ/kg is the calorific value of light oil.
- See relevant brochure for burner capacity/back pressure graphs: The graphs indicate the burner operating range. For example, the boiler back pressure with a burner capacity of 7,220 kW is 18 mbar. Looking at the adjoining graph, plot your burner capacity along the horizontal axis. On the vertical axis plot your boiler back-pressure. Where the two lines meet, defines the required burner type. The optimum burner is best chosen by ensuring that the plotted operating point is as close as possible to the right hand edge of the corresponding operating envelope. Different fuels and capacity regulation methods require separate graphs. The fuel calorific value is stated on the graphs.
- Gas and dual fuel burner valve selection: Choose a large enough valve, using the gas valve selection table. Note that the values in the selection table apply when the furnace back pressure is 0 mbar. Therefore, you must subtract the furnace back pressure from the actual gas inlet pressure and choose the valve on the basis of the value thus obtained. The ratings shown in the table apply to natural gas.  
 For example, using a gas inlet pressure of 100 mbar, a required burner capacity of 7,220 kW, and required burner capacity is 7,220 kW, the effective pressure will be 100 mbar - 18 mbar = 82 mbar. For the GP-700 M burner, for example, you should choose a valve allowing a minimum burner capacity of 7,220 kW with 82 mbar gas inlet pressure → in this case, valve DN 100.
- Check that the outer dimensions of the burner, especially those of the combustion head, are suitable for the application; the length of the combustion head should be such that, when mounted, the combustion head is even with the furnace wall or about 10 to 20 mm inside the furnace (see 'Masonry' figure).
- Check the flame dimensions in the flame dimension table. Please note that the flame must not come in to contact the walls of the furnace.
- Accessory requirements must also be taken into consideration: gas pressure regulator, oil pumping unit, boiler thermostats/ pressostats.

## B. Equations and rules of thumb

- Burner capacity = boiler capacity / 0.9 (when boiler efficiency is 90 %)
- Steam boilers: 1 ton/h steam ≈ 700 kW boiler capacity
- Light oil: 1 kg/h ≈ 11.86 kW burner capacity with calorific value 42.7 MJ/kg
- Heavy oil: 1 kg/h ≈ 11.22 kW burner capacity with calorific value 40.5 MJ/kg
- Natural gas: 1 m<sup>3</sup>/h ≈ 10 kW burner capacity with calorific value 35.84 MJ/m<sup>3</sup>n
- The amount of combustion air:
  - Gas burners: required amount of combustion air for each 10 kW of burner capacity is 12 to 13 m<sup>3</sup>/h.
  - Oil burners: required amount of combustion air for each kilo of oil burned [kg/h] is 13.5 m<sup>3</sup>/h.
- Oil pumping, filtering, and preheating unit (Oilon HotBox) is required when firing heavy fuel oil. When the burner capacity is more than 2 MW, a transfer pump unit (Oilon SPY) is always needed, including for use with light fuel oil. The required minimum pump output [kg/h] can be calculated as follows: Required minimum output [kg/h] = (oil flow to be burned in kg/h + 150 to 200 kg/h)\* 1.25 to 1.3, where the expression inside the parentheses indicates the preheated oil flow to each burner.

## An example of burner selection

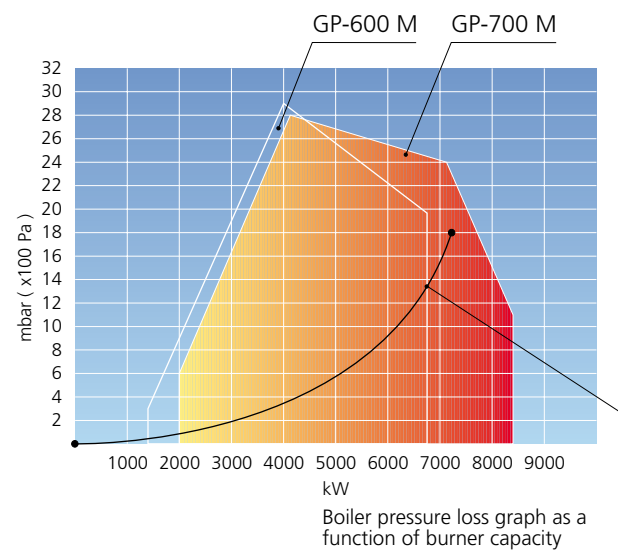

The max. capacity of a hot water boiler is 6,500 kW, efficiency 0.9, and the corresponding burner capacity 6,500 kW / 0.9 = 7,220 kW. The graph indicates that a suitable gas burner for this capacity is the GP-700 M, as the pressure loss value for the boiler is located inside the area for the GP-700 M burner on the capacity/back pressure graph. The GP-600 M can also be used for this application, provided that the full boiler capacity is not required. Remember to take efficiency into account when relating the boiler pressure loss information to the burner capacity/back pressure graph.



# Light oil burners

## KP-300 M-II

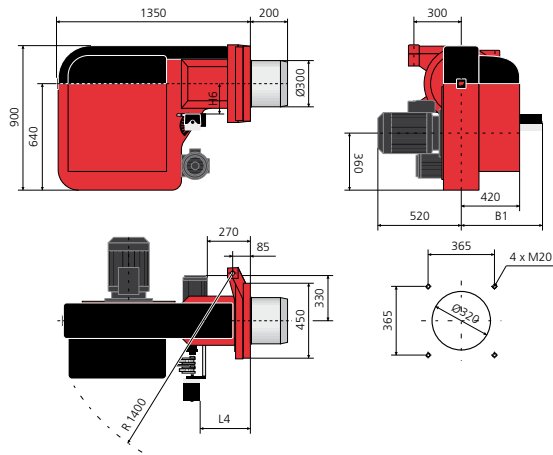

## KP-400 M-I...-700 M-II

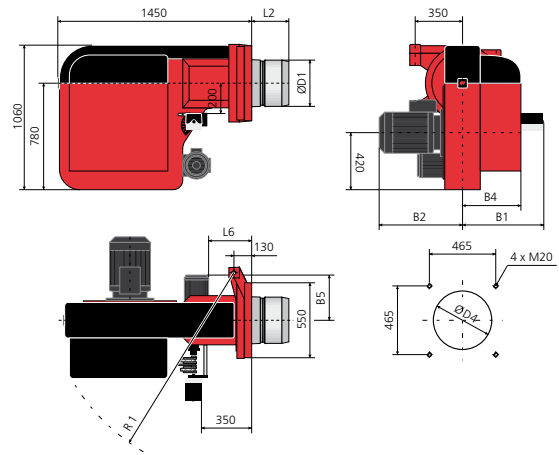

BURNER	L4	H6	B1
KP-300 M-II	330	170	570

BURNER	L2	L6	B1	B2	B4	B5	Ø D1	Ø D4	R1
KP-400 M-I	264	280	590	630	440	330	340	400	1450
KP-500 M	264	280	590	630	440	330	340	400	1450
KP-600 M	285	280	590	630	440	330	370	430	1450
KP-700 M	338	250	640	730	490	360	395	455	1550
KP-700 M-II	338	250	640	780	490	360	395	455	1550

## Technical Data

BURNER	KP-300 M-II
Capacity kg/h	80 - 380
kW	950 - 4500
Fan motor 3~ 400 V 50 Hz Output kW Current A Speed rpm	7.5 15.0 2870
Oil hose connection - suction - return	R1" R1"
Oil pump - Motor 3~ 400 V 50 Hz Output kW Current A Speed rpm	TA4 1.5 4.8 2860
Weight kg	340

Note! The weight varies according to delivery contents.

BURNER	KP-400 M-I	KP-500 M	KP-600 M	KP-700 M	KP-700 M-II
Capacity kg/h	110 - 420	120 - 515	120 - 570	170 - 710	170 - 821
kW	1300 - 5000	1400 - 6070	1400 - 6750	2000 - 8400	2000 - 9700
Fan motor 3~ 400 V 50 Hz Output kW Current A Speed rpm	11.0 21.0 2925	11.0 21.0 2925	15.0 28.03 2925	18.5 34.0 2930	22.0 41.0 2940
Oil hose connection - suction - return	R1" R1"	R1" R1"	R1" R1"	R1" R1"	R1" R1"
Oil pump - Motor 3~ 400 V 50 Hz Output kW Current A Speed rpm	TA4 1.5 4.8 2860	TA5 2.2 5.4 2870	TA5 2.2 5.4 2870	T3 4.0 8.1 2840	T4 4.0 8.1 2840
Regulating valve				TV 4001	TV 4001
Weight kg	465	470	480	500	535

# Light oil burners

## PI-diagrams

**KP-300 M-II...-600 M**

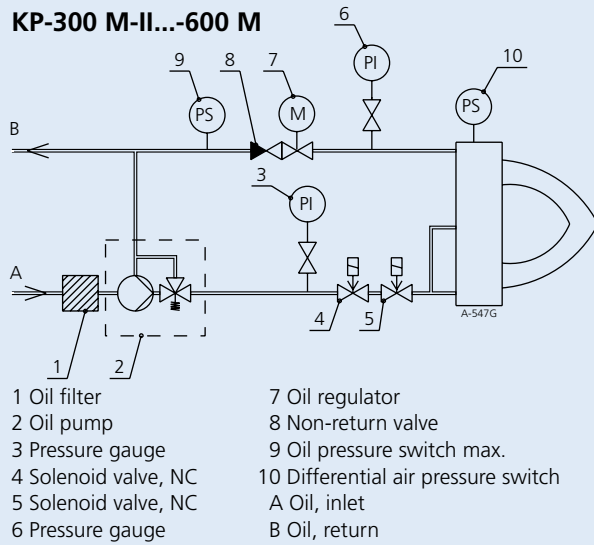

- 1 Oil filter
- 2 Oil pump
- 3 Pressure gauge
- 4 Solenoid valve, NC
- 5 Solenoid valve, NC
- 6 Pressure gauge
- 7 Oil regulator
- 8 Non-return valve
- 9 Oil pressure switch max.
- 10 Differential air pressure switch
- A Oil, inlet
- B Oil, return

**KP-700 M...-700 M-II**

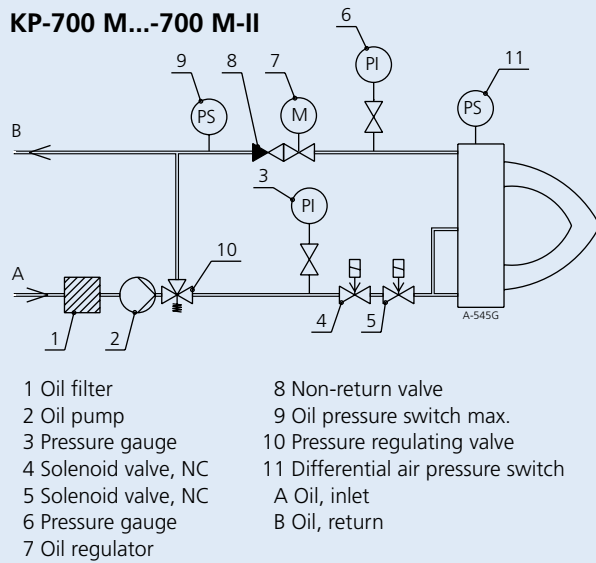

- 1 Oil filter
- 2 Oil pump
- 3 Pressure gauge
- 4 Solenoid valve, NC
- 5 Solenoid valve, NC
- 6 Pressure gauge
- 7 Oil regulator
- 8 Non-return valve
- 9 Oil pressure switch max.
- 10 Pressure regulating valve
- 11 Differential air pressure switch
- A Oil, inlet
- B Oil, return

### Scope of delivery

Burners include following equipment:

• standard delivery    o option

	KP-300 M-II...-700 M-II
Hinge flange with limit switch	•
Burner flange gasket	•
Oil nozzle/nozzles	•
Solenoid valves for oil	•
Oil pump with pressure regulating valve	•
Oil pump motor, separate	•
Non-return valve	•
Pressure gauge/gauges for oil	•
Pressure switch for return oil	•
Deaerator	
2 oil hoses, length 3000 mm	•
Oil filter	•
Pressure gauge for control of inlet oil	o
Pressure switch for control of inlet oil	o
Controller unit for regulation of air/oil ratio incl.: - oil regulator - servomotor	•
WiseDrive (electronic ratio control) for regulating the air/oil ratio, incl.: - oil regulator - servomotor for oil regulator - servomotor for air dampers - servomotor for combustion head regulation	o
Potentiometer fitted in servomotor	o
Differential air pressure switch	•
Ignition transformer	•
Ignition cables and electrodes	•
Flame sensor	•
Inbuilt combustion air fan with direct-driven electric motor	•
Air dampers	•
Separate servomotor for air dampers	
Pressure gauge for fan pressure	o
Manual	•

# Light oil burners

## Capacity/back pressure graphs

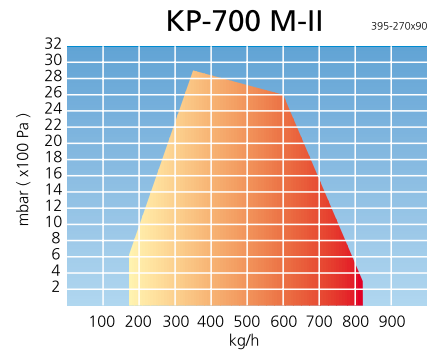
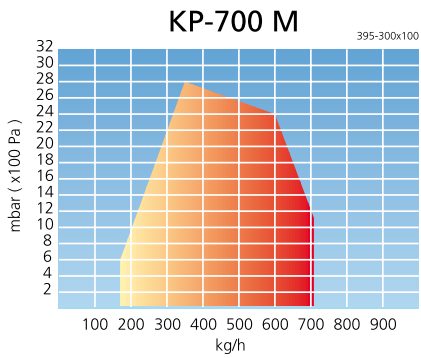
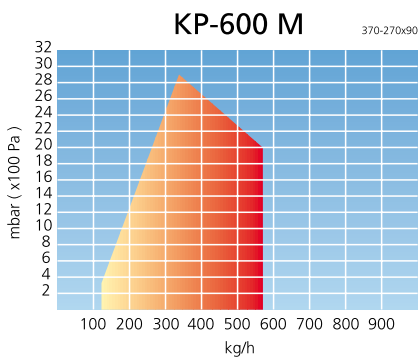
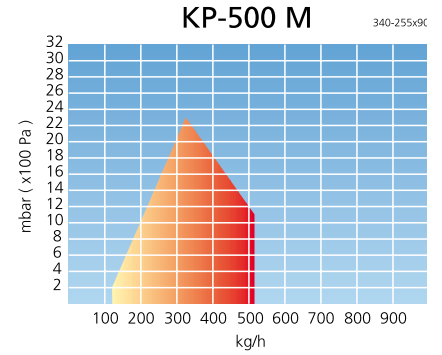
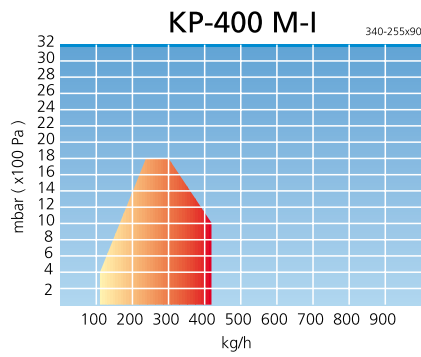
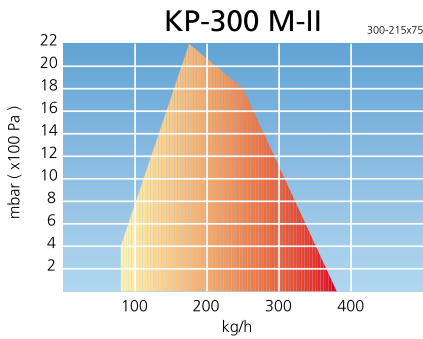

Light fuel oil: 1 kg/h = 11.86 kW





# Heavy oil burners

## RP-300 M-II

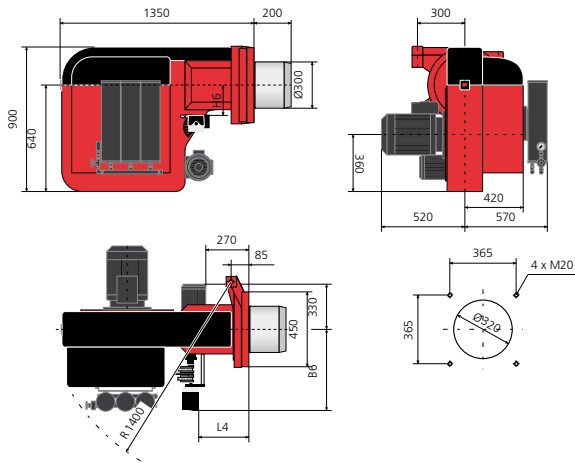

## RP-400 M-I...-700 M-II

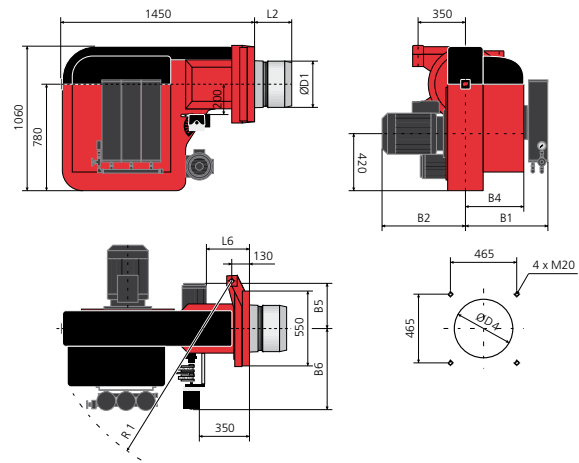

BURNER	L4	H6	B6
RP-300 M-II	330	170	570

BURNER	L2	L6	B1	B2	B4	B5	B6	Ø D1	Ø D4	R1
RP-400 M-I	264	280	620	630	440	330	590	340	400	1450
RP-500 M	264	280	620	630	440	330	590	340	400	1450
RP-600 M	285	280	620	630	440	330	590	370	430	1450
RP-700 M	338	250	670	730	490	360	640	395	455	1550
RP-700 M-II	338	250	670	780	490	360	640	395	455	1550

## Technical Data

BURNER	RP-300 M-II
Capacity kg/h	80 - 380
kW	900 - 4200
Fan motor	
3~ 400 V 50 Hz	
Output kW	7,5
Current A	15,0
Speed rpm	2870
Oil hose connection	
- suction	R1"
- return	R½"
Oil pump	SPF10R46
- Motor	
3~ 400 V 50 Hz	
Output kW	1,5
Current A	4,8
Speed rpm	2860
Preheater	
3~ 400 V 50 Hz	
Output kW	12
Weight kg	390

Note! The weight varies according to delivery contents.

BURNER	RP-400 M-I	RP-500 M	RP-600 M	RP-700 M	RP-700 M-II
Capacity kg/h	110 - 420	140 - 535	125 - 600	170 - 710	170 - 850
kW	1300 - 4700	1585 - 6060	1400 - 6750	1900 - 7900	1900 - 9500
Fan motor					
3~ 400 V 50 Hz					
Output kW	11.0	11.0	15.0	18.5	22.0
Current A	21.0	21.0	28.0	34.0	41.0
Speed rpm	2925	2925	2925	2930	2940
Oil hose connection					
- suction	R1"	R1"	R1"	R1"	R1"
- return	R½"	R½"	R½"	R½"	R½"
Oil pump	SPF10R56	SPF10R56	SPF20R38	SPF20R56	SPF20R56
- Motor					
3~ 400 V 50 Hz					
Output kW	2.2	2.2	2.2	4.0	4.0
Current A	5.4	5.4	5.4	8.1	8.1
Speed rpm	2870	2870	2870	2840	2840
Preheater					
3~ 400 V 50 Hz					
Output kW	18	18	18	24	30
Weight kg	540	540	545	610	655

# Heavy oil burners

## PI-diagrams

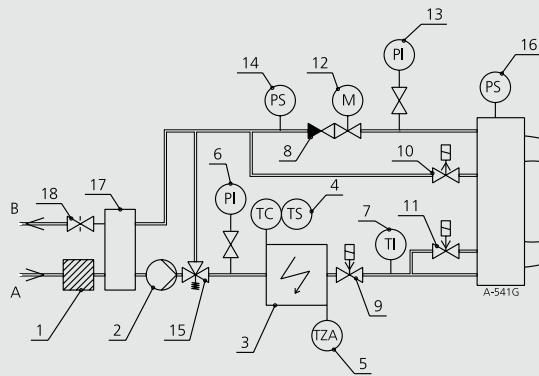

## RP-300 M-II...-700 M-II

- |  |                                     |
|--|-------------------------------------|
| 1 Oil filter                             | 10 Solenoid valve, NO               |
| 2 Oil pump, without plug                 | 11 Solenoid valve, NC               |
| 3 Preheater                              | 12 Oil regulator                    |
| 4 Temperature regulation/<br>lower limit | 13 Pressure gauge                   |
| 5 Limit thermostat                       | 14 Pressure switch, max.            |
| 6 Pressure gauge                         | 15 Pressure regulating valve        |
| 7 Thermometer                            | 16 Differential air pressure switch |
| 8 Non-return valve                       | 17 Deaerator                        |
| 9 Solenoid valve, NC                     | 18 Drilled ball valve               |
|  | A Oil, inlet                        |
|  | B Oil, return                       |

## Scope of delivery

Burners include following equipment:

• standard delivery    o option

	RP-300 M-II...-700 M-II
Hinge flange with limit switch	•
Burner flange gasket	•
Oil nozzle/nozzles	•
Heating cartridge for oil nozzle	o
Solenoid valves for oil	•
Heating cartridge for solenoid valves	•
Oil pump with pressure regulating valve	•
Heating cartridge for oil pump	o
Separate motor for oil pump	•
Non-return valve	•
Pressure gauge/gauges for oil	•
Thermometer	•
Pressure switch for return oil	•
Deaerator	•
Electric preheater incl.:	•
- limit thermostat	
- temperature sensor	
2 oil hoses, length 3000 mm	•
Electric tracing cables for burner oil pipes	o
Electric tracing cables for oil hoses	o
Oil filter	•
Pressure gauge for control of inlet oil	o
Pressure switch for control of inlet oil	o
Controller unit for regulation of air/oil ratio incl.:	•
- oil regulator	
- servomotor	
WiseDrive (electronic ratio control) for regulating the air/oil ratio, incl.:	o
- oil regulator	
- servomotor for oil regulator	
- servomotor for air dampers	
- servomotor for combustion head regulation	
Potentiometer fitted in servomotor	o
Differential air pressure switch	•
Ignition transformer	•
Ignition cables and electrodes	•
Flame sensor	•
Inbuilt combustion air fan with direct-driven electric motor	•
Air dampers	•
Separate servomotor for air dampers	
Pressure gauge for fan pressure	o
Manual	•

# Heavy oil burners

## Capacity/back pressure graphs

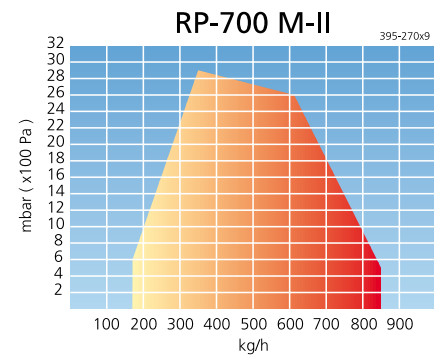
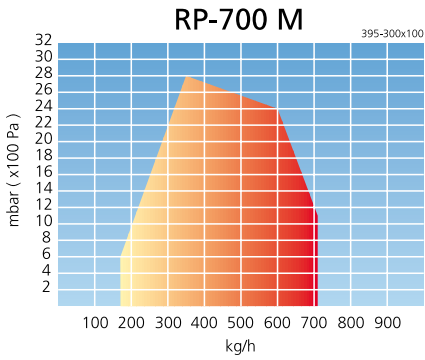
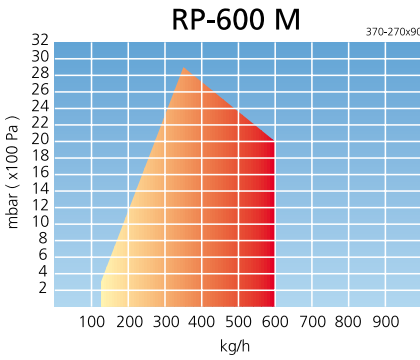
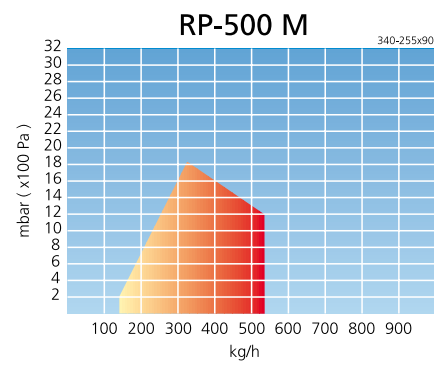
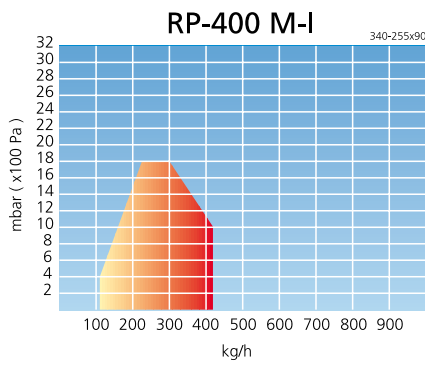
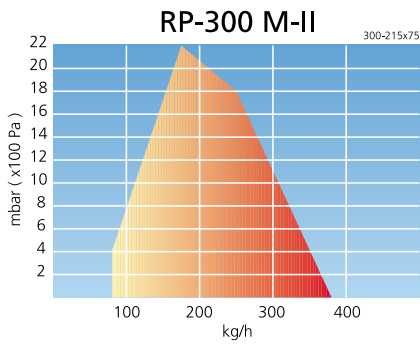

Heavy fuel oil: 1 kg/h = 11.22 kW

0

# Gas burners

## GP-300 M-II

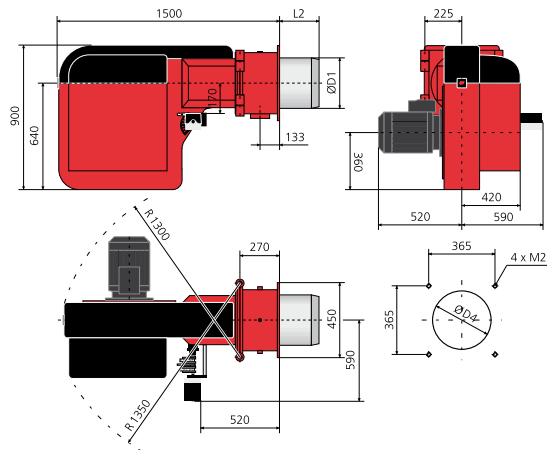

BURNER	L2	Ø D1	Ø D4
GP-300 M-II	246	320	380

## GP-400 M-I...-700 M-II

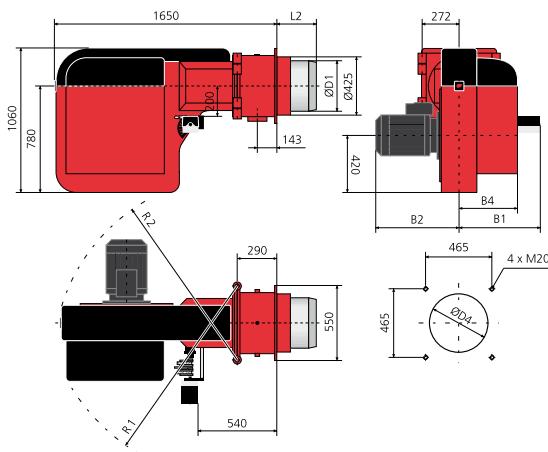

BURNER	L2	B1	B2	B4	Ø D1	Ø D4	R1	R2
GP-400 M-I	290	520	630	440	370	440	1500	1400
GP-500 M	290	520	630	440	370	440	1500	1400
GP-600 M	310	520	630	440	395	455	1500	1400
GP-700 M	310	570	730	490	395	455	1600	1500
GP-700 M-II	310	570	780	490	395	455	1600	1500

# Gas burners

## Technical Data

BURNER	GP-300 M-II
Capacity kW	950 - 4500
Fan motor 3~ 400 V 50 Hz	
Output kW	7.5
Current A	15.0
Speed rpm	2870
Weight kg	320

BURNER	GP-400 M-I	GP-500 M	GP-600 M	GP-700 M	GP-700 M-II
Capacity kW	1300 - 5000	1400 - 6070	1400 - 6750	2000 - 8400	2000 - 9500
Fan motor 3~ 400 V 50 Hz					
Output kW	11.0	11.0	15.0	18.5	22.0
Current A	21.0	21.0	28.0	34.0	41.0
Speed rpm	2925	2925	2925	2930	2940
Weight kg	450	450	460	535	565

Note! The weight varies according to delivery contents.

## PI-diagrams

### GP-300 M-II...-700 M-II

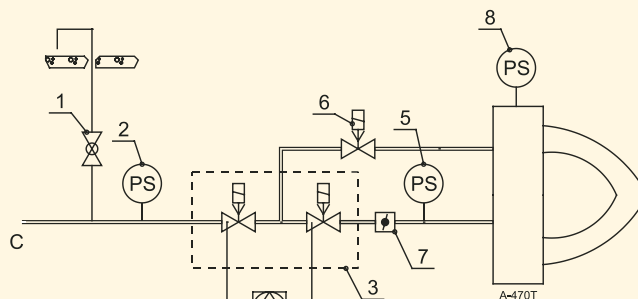

- 1 Ball valve, blow-off
- 2 Pressure switch, min.
- 3 Double solenoid valve, NC
- 4 Valve leak tester
- 5 Pressure switch, max.
- 6 Solenoid valve, NC, ignition gas
- 7 Gas butterfly valve
- 8 Differential air pressure switch
- C Gas

# Gas burners

## Scope of delivery

Burners include following equipment:

• standard delivery    o option

	GP-300 M-II ...-700 M-II
Hinge flange with limit switch	•
Burner flange gasket	•
Controller unit for regulation of air/gas ratio incl.: - servomotor - gas butterfly valve	•
WiseDrive (electronic ratio control) for regulating the air/gas ratio, incl.: - gas butterfly valve - servomotor for gas butterfly valve - servomotor for air dampers - servomotor for combustion head regulation	o
Potentiometer fitted in servomotor	o
Gas nozzle	•
Pressure gauge for measuring the pressure in gas nozzle	o
Max. gas pressure switch	•
Differential air pressure switch	•
Ignition transformer	•
Ignition cables and electrodes	•
Flame sensor	•
Inbuilt combustion air fan with direct-driven electric motor	•
Air dampers	•
Pressure gauge for fan pressure	o
Operating switches	•
Elbow 90°	•
Double solenoid valve for gas incl.: - gas pressure switch, min. - 2 gas valves - automatic valve leak tester - ball valve, blow-off (loose)	•
Solenoid valve for ignition gas	•
Manual	•



# Gas burners

## Capacity/back pressure graphs

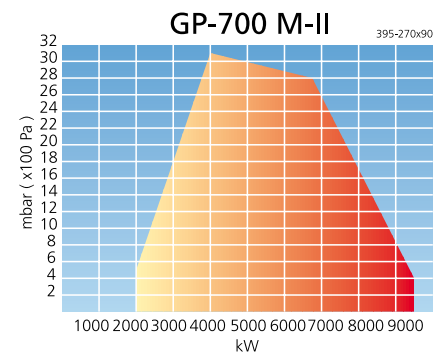
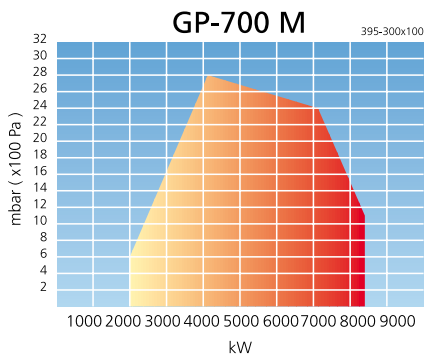
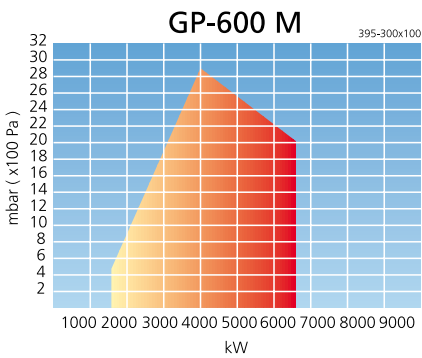
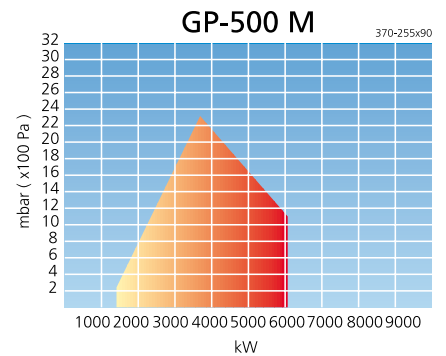
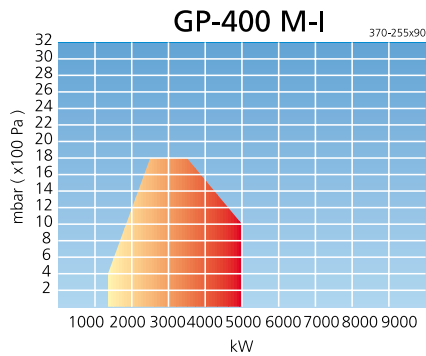
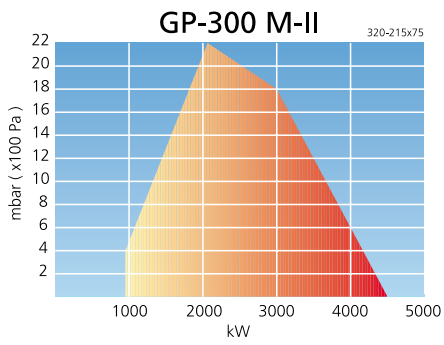

Natural gas: gases of 2<sup>nd</sup> family, groups H and E (equipment category I<sub>2R</sub>)

# Dual fuel burners, light fuel oil/gas

## GKP-300 M-II

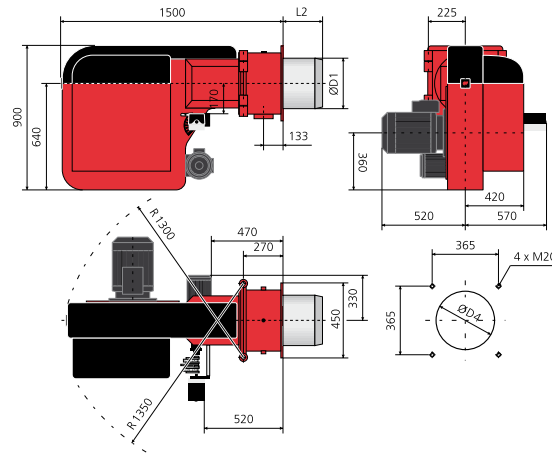

BURNER	L2	Ø D1	Ø D4
GKP-300 M-II	246	320	380

## GKP-400 M-I...-700 M-II

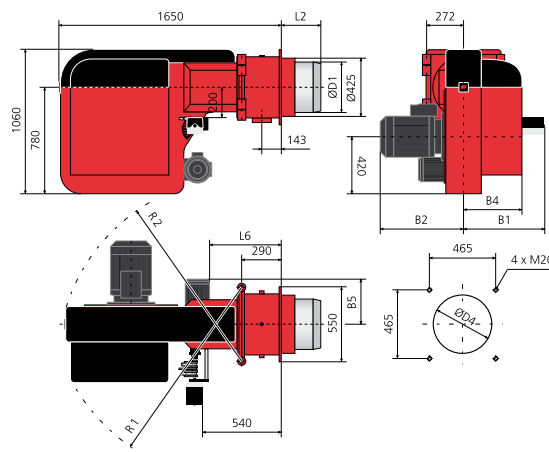

BURNER	L2	L6	B1	B2	B4	B5	Ø D1	Ø D4	R1	R2
GKP-400 M-I	290	480	590	630	440	350	370	440	1500	1400
GKP-500 M	290	480	590	630	440	350	370	440	1500	1400
GKP-600 M	310	480	590	630	440	350	395	455	1500	1400
GKP-700 M	310	450	640	730	490	360	395	455	1600	1500
GKP-700 M-II	310	450	640	780	490	360	395	455	1600	1500

# Dual fuel burners, light fuel oil/gas

## Technical Data

BURNER	GKP-300 M-II
Capacity kg/h	80 - 380
kW	950 - 4500
Fan motor	
3~ 400 V 50 Hz	
Output kW	7.5
Current A	15.0
Speed rpm	2870
Oil hose connection	
- suction	R1"
- return	R1"
Oil pump	TA4
- Motor	
3~ 400 V 50 Hz	
Output kW	1.5
Current A	4.8
Speed rpm	2860
Weight kg	390

Note! The weight varies according to delivery contents.

BURNER	GKP-400 M-I	GKP-500 M	GKP-600 M	GKP-700 M	GKP-700 M-II
Capacity kg/h	110 - 420	120 - 515	120 - 570	170 - 710	180 - 821
kW	1300 - 5000	1400 - 6070	1400 - 6750	2000 - 8400	2100 - 9500
Fan motor					
3~ 400 V 50 Hz					
Output kW	11.0	11.0	15.0	18.5	22.0
Current A	21.0	21.0	28.0	34.0	41.0
Speed rpm	2925	2925	2925	2930	2940
Oil hose connection					
- suction	R1"	R1"	R1"	R1"	R1"
- return	R1"	R1"	R1"	R1"	R1"
Oil pump	TA4	TA5	TA5	T3	T4
- Motor					
3~ 400 V 50 Hz					
Output kW	1.5	2.2	2.2	4.0	4.0
Current A	4.8	5.4	5.4	8.1	8.1
Speed rpm	2860	2870	2870	2840	2840
Regulating valve				TV4001	TV4001
Weight kg	505	510	520	565	680

## PI-diagrams

### GKP-300 M-II...-600 M

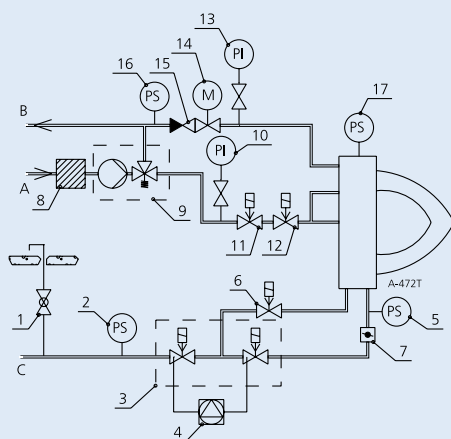

- |                                    |                                     |
|------------------------------------|-------------------------------------|
| 1 Ball valve, blow-off             | 12 Solenoid valve, NC               |
| 2 Pressure switch, min.            | 13 Pressure gauge                   |
| 3 Double solenoid valve, NC        | 14 Oil regulator                    |
| 4 Valve leak tester                | 15 Non-return valve                 |
| 5 Pressure switch, max.            | 16 Pressure switch for oil, max.    |
| 6 Solenoid valve, NC, ignition gas | 17 Differential air pressure switch |
| 7 Gas butterfly valve              | A Oil, inlet                        |
| 8 Oil filter                       | B Oil, return                       |
| 9 Oil pump, with plug              | C Gas                               |
| 10 Pressure gauge                  |                                     |
| 11 Solenoid valve, NC              |                                     |

### GKP-700 M...-700 M-II

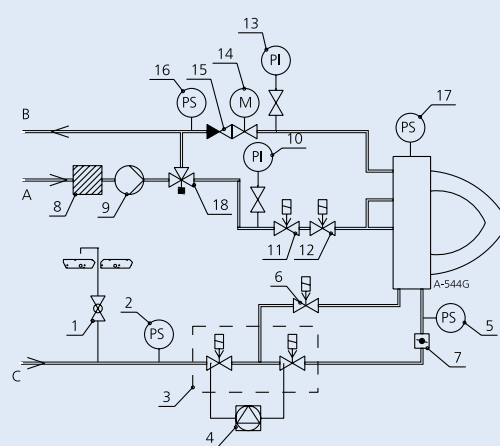

- |                                    |                                     |
|------------------------------------|-------------------------------------|
| 1 Ball valve, blow-off             | 12 Solenoid valve, NC               |
| 2 Pressure switch, min.            | 13 Pressure gauge                   |
| 3 Double solenoid valve, NC        | 14 Oil regulator                    |
| 4 Valve leak tester                | 15 Non-return valve                 |
| 5 Pressure switch, max.            | 16 Pressure switch for oil, max.    |
| 6 Solenoid valve, NC, ignition gas | 17 Differential air pressure switch |
| 7 Gas butterfly valve              | 18 Pressure regulating valve        |
| 8 Oil filter                       | A Oil, inlet                        |
| 9 Oil pump                         | B Oil, return                       |
| 10 Pressure gauge                  | C Gas                               |
| 11 Solenoid valve, NC              |                                     |

# Dual fuel burners, light fuel oil/gas

## Scope of delivery

Burners include following equipment:

• standard delivery

o option

	GKP-300 M-II...-700 M-II
Hinge flange with limit switch	•
Burner flange gasket	•
Oil nozzle/nozzles	•
Solenoid valves for oil	•
Oil pump with pressure regulating valve	•
Separate motor for oil pump	•
Non-return valve	•
Pressure gauge/gauges for oil	•
Pressure switch for return oil	•
Deaerator	o
2 oil hoses, length 3000 mm	•
Oil filter	•
Pressure gauge for control of inlet oil	o
Pressure switch for control of inlet oil	o
Controller unit for regulation of air/oil/gas ratio incl.: - oil regulator - gas butterfly valve - servomotor	•
WiseDrive (electronic ratio control) for regulating the air/oil/gas ratio, incl.: - oil regulator - gas butterfly valve - servomotor for oil regulator - servomotor for gas butterfly valve - servomotor for air dampers - servomotor for combustion head regulation	o
Potentiometer fitted in servomotor	o
Gas nozzle	•
Pressure gauge for measuring the pressure in gas nozzle	o
Gas pressure switch, max.	•
Differential air pressure switch	•
Ignition transformer	•
Ignition cables and electrodes	•
Flame sensor	•
Inbuilt combustion air fan with direct-driven electric motor	•
Air dampers	•
Pressure gauge for fan pressure	o
Elbow 90°	•
Double solenoid valve for gas incl.: - pressure switch for gas, min. - 2 gas valves - automatic valve leak tester - ball valve, blow-off (loose)	•
Solenoid valve for ignition gas	•
Manual	•

# Dual fuel burners, light fuel oil/gas

## Capacity/back pressure graphs

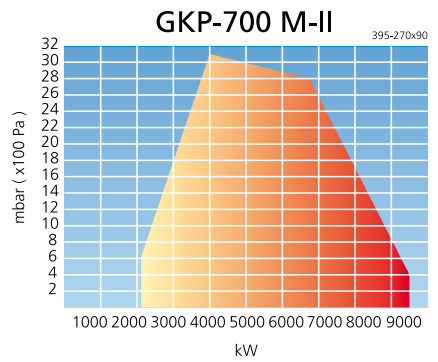
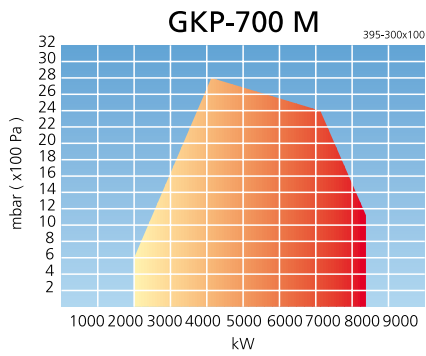
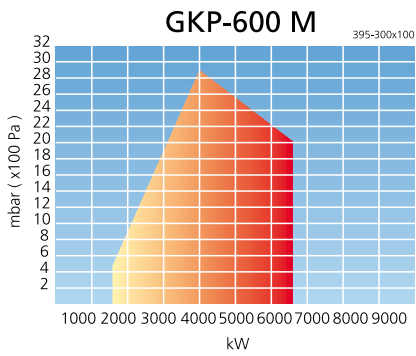
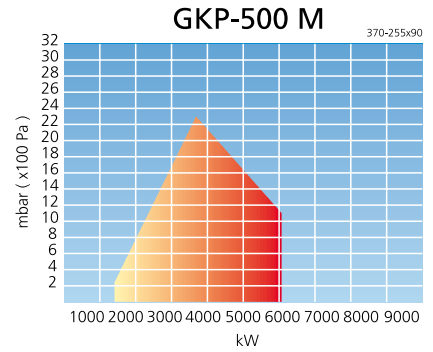
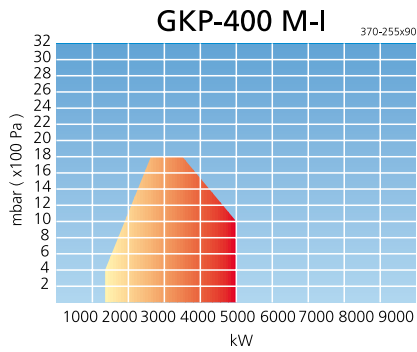
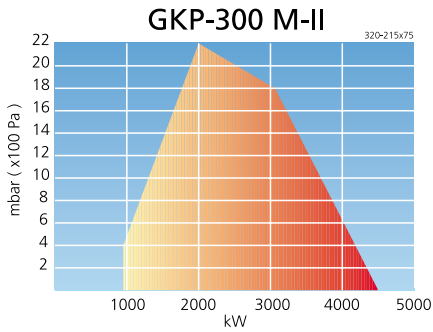

Natural gas: gases of 2<sup>nd</sup> family, groups H and E (equipment category I<sub>2R</sub>)

# Dual fuel burners, heavy fuel oil/gas

## GRP-300 M-II

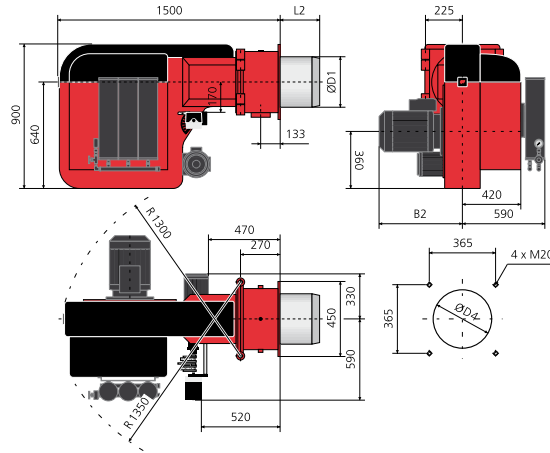

BURNER	L2	Ø D1	Ø D4
GRP-300 M-II	246	320	380

## GRP-400 M-I...-700 M-II

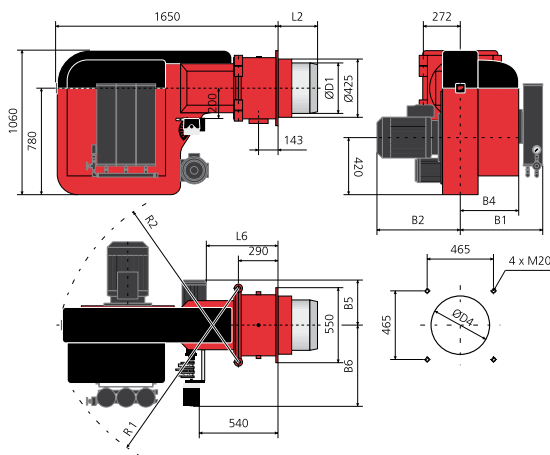

BURNER	L2	L6	B1	B2	B4	B5	B6	Ø D1	Ø D4	R1	R2
GRP-400 M-I	290	480	620	630	440	350	590	370	440	1500	1400
GRP-500 M	290	480	620	630	440	350	590	370	440	1500	1400
GRP-600 M	310	480	620	630	440	350	590	395	455	1500	1400
GRP-700 M	310	450	670	730	490	360	640	395	455	1600	1500
GRP-700 M-II	310	450	670	780	490	360	640	395	455	1600	1500



# Dual fuel burners, heavy fuel oil/gas

## Technical Data

BURNER	GRP-300 M-II
Capacity kg/h kW	80 - 380 900 - 4200
Fan motor 3~ 400 V 50 Hz Output kW Current A Speed rpm	7.5 15.0 2870
Oil hose connection - suction - return	R1" R½"
Oil pump - Motor 3~ 400 V 50 Hz Output kW Current A Speed rpm	SPF10R46 1.5 4.8 2860
Preheater 3~ 400 V 50 Hz Capacity kW	12
Weight kg	440

Note! The weight varies according to delivery contents.

BURNER	GRP-400 M-I	GRP-500 M	GRP-600 M	GRP-700 M	GRP-700 M-II
Capacity kg/h kW	110 - 420 1300 - 4700	140 - 535 1585 - 6050	125 - 600 1400 - 6750	170 - 710 1900 - 7900	170 - 850 1900 - 9500
Fan motor 3~ 400 V 50 Hz Output kW Current A Speed rpm	11.0 21.0 2925	11.0 21.0 2925	15.0 28.0 2925	18.5 34.0 2930	22.0 41.0 2940
Oil hose connection - suction - return	R1" R½"	R1" R½"	R1" R½"	R1" R½"	R1" R½"
Oil pump - Motor 3~ 400 V 50 Hz Output kW Current A Speed rpm	SPF10R56 2.2 5.4 2870	SPF10R56 2.2 5.4 2870	SPF20R38 2.2 5.4 2870	SPF120R56 4.0 8.1 2840	SPF20R56 4.0 8.1 2840
Preheater 3~ 400 V 50 Hz Capacity kW	18	18	18	24	30
Weight kg	570	575	590	660	710

## PI-diagrams

### GRP-300 M-II...-700 M-II

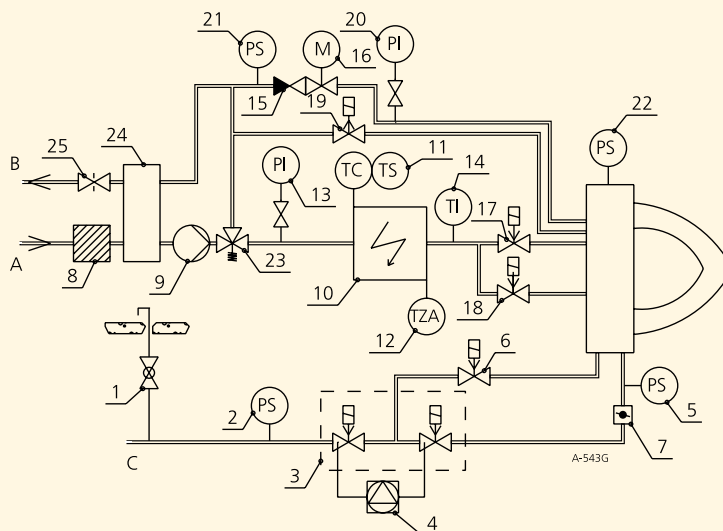

- 1 Ball valve, blow-off
  - 2 Pressure switch, min.
  - 3 Double solenoid valve, NC
  - 4 Valve leak tester
  - 5 Pressure switch, max.
  - 6 Solenoid valve, NC, ignition gas
  - 7 Gas butterfly valve
  - 8 Oil filter
  - 9 Oil pump, with plug
  - 10 Preheater
  - 11 Temperature regulation/lower limit
  - 12 Limit thermostat
  - 13 Pressure gauge
  - 14 Thermometer
  - 15 Non-return valve
  - 16 Oil regulator
  - 17 Solenoid valve, NC
  - 18 Solenoid valve, NC
  - 19 Solenoid valve, NO
  - 20 Pressure gauge
  - 21 Pressure switch, max.
  - 22 Differential air pressure switch
  - 23 Pressure regulating valve
  - 24 Deaerator
  - 25 Drilled ball valve
- A Oil, inlet  
B Oil, return  
C Gas

# Dual fuel burners, heavy fuel oil/gas

## Scope of delivery

Burners include following equipment:

• standard delivery

o option

	GRP-300 M-II... -700 M-II
Hinge flange with limit switch	•
Burner flange gasket	•
Oil nozzle/nozzles	•
Heating cartridge for oil nozzle	o
Solenoid valves for oil	•
Heating cartridge for solenoid valves	•
Oil pump with pressure regulating valve	•
Heating cartridge for oil pump	o
Separate motor for oil pump	•
Non-return valve	•
2 pressure gauges for oil	•
Thermometer	•
Pressure switch for return oil	•
Deaerator for oil	•
Electric preheater incl.: - limit thermostat - temperature sensor	•
2 oil hoses, length 3000 mm	•
Electric tracing cables for burner oil pipes	o
Electric tracing cables for oil hoses	o
Oil filter	•
Pressure gauge for control of inlet oil	o
Pressure switch for control of inlet oil	o
Controller unit for regulation of air/oil/gas ratio incl.: - oil regulator - gas butterfly valve - servomotor	•
WiseDrive (electronic ratio control) for regulating the air/oil/gas ratio, incl.: - oil regulator - gas butterfly valve - servomotor for oil regulator - servomotor for gas butterfly valve - servomotor for air dampers - servomotor for combustion head regulation	o
Potentiometer fitted in servomotor	o
Gas nozzle	•
Pressure gauge for measuring the pressure in gas nozzle	o
Gas pressure switch, max.	•
Differential air pressure switch	•
Ignition transformer	•
Ignition cables and electrodes	•
Flame sensor	•
Inbuilt combustion air fan with direct-driven electric motor	•
Air dampers	•
Pressure gauge for fan pressure	o
Elbow 90°	•
Double solenoid valve for gas incl.: - gas pressure switch, min. - 2 gas valves - automatic valve leak tester - ball valve, blow-off (loose)	•
Solenoid valve for ignition gas	•
Manual	•

# Dual fuel burners, heavy fuel oil/gas

## Capacity/back pressure graphs

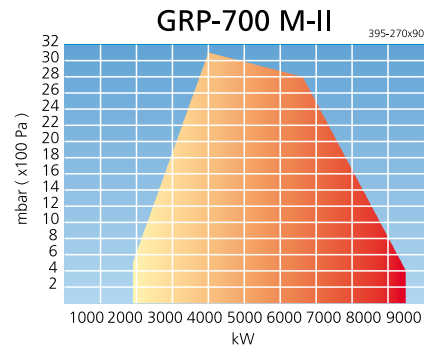
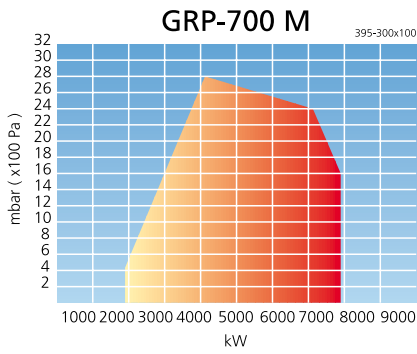
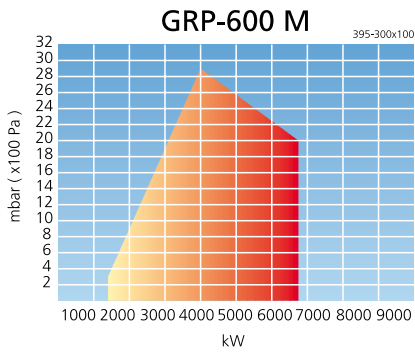
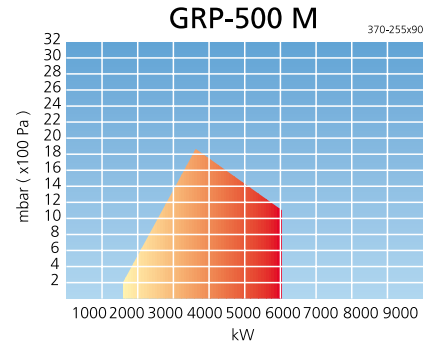
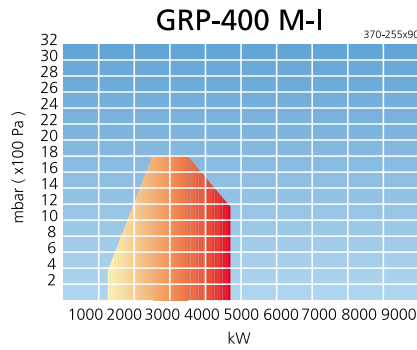
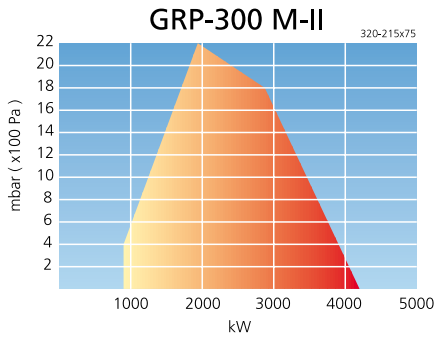

Natural gas: gases of 2<sup>nd</sup> family, groups H and E (equipment category I<sub>2R</sub>)  
 Heavy fuel oil: 1 kg/h = 11.86 kW

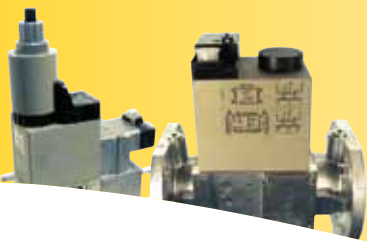

# Gas valve selection table

## BURNER SERIES 300

BURNER	GAS VALVE		BURNER MAX. CAPACITY kW *)					COMBUSTION HEAD
	SIZE DN	TYPE **)	GAS INLET PRESSURE mbar					
			20	30	50	100	150	
GP/GKP/GRP-300 M-II	50	DMV-D		1730	2230	3160	3870	320
GP/GKP/GRP-300 M-II	65	DMV	2090	2560	3310	4500	4500	320
GP/GKP/GRP-300 M-II	80	DMV	2840	3480	4490	4500	4500	320
GP/GKP/GRP-300 M-II	100	DMV	3370	4130	4500	4500	4500	320
GP/GKP/GRP-300 M-II	125	DMV	3840	4500	4500	4500	4500	320

## BURNER SERIES 400...700

BURNER	GAS VALVE		BURNER MAX. CAPACITY kW *)					COMBUSTION HEAD
	SIZE DN	TYPE **)	GAS INLET PRESSURE mbar					
			20	30	50	100	150	
GP/GKP/GRP-400 M-I	50	DMV-D			2260	3200	3920	370
	65	DMV		2630	3390	4790	5000	370
	80	DMV	3050	3730	4820	5000	5000	370
	100	DMV	3810	4670	5000	5000	5000	370
	125	DMV	4780	5000	5000	5000	5000	370
GP/GKP/GRP-500 M	65	DMV			3390	4790	5870	370
	80	DMV	3050	3730	4820	6070	6070	370
	100	DMV	3810	4670	6070	6070	6070	370
	125	DMV	4780	5860	6070	6070	6070	370
GP/GKP/GRP-600 M	65	DMV			3430	4850	5940	395
	80	DMV	3110	3810	4900	6750	6750	395
	100	DMV	3900	4780	6170	6750	6750	395
	125	DMV	4960	6080	6750	6750	6750	395
GP/GKP/GRP-700 M	80	DMV		3810	4920	6960	8400	395
	100	DMV	3900	4780	6170	8400	8400	395
	125	DMV	4960	6080	7840	8400	8400	395
GP/GKP/GRP-700 M-II	80	DMV			5020	7100	8700	395
	100	DMV		4940	6370	9010	9500	395
	125	DMV	5080	6620	8030	9500	9500	395

**NOTE!** If the gas inlet pressure is less than 20 mbar or if the gas used is not among those mentioned, evaluation must be made case-specifically.

\*) The max. capacities shown by the table are achieved when the boiler back pressure is 0.

Natural gas 1 m<sup>3</sup>/h = 10 kW

\*\*\*) or corresponding type

Gas inlet pressure (Pmax) at burner

- max. 500 mbar when using DMV(D) valve

# Gas elbow

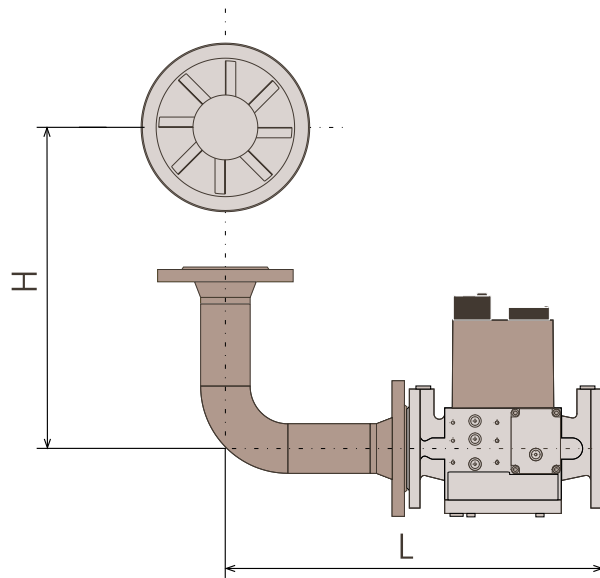

GAS ELBOW DIMENSIONS WITH DIFFERENT VALVES						
		DN50	DN65	DN80	DN100	DN125
	H	L	L	L	L	L
GP/GKP/GRP-300 M-II	450	590	640	580	620	700
GP/GKP/GRP-400...700 M-II	525	640	690	715	660	735

Other dimensions available on special request

## Low NOx technology for lower combustion gas emissions

The development of the Low NOx burners increased the Oilon burner selection considerably. The greatest improvement took place at the burner combustion head, where changes to the flow of the combustion gases enable lower NOx emissions. Various tests and practical experience prove that the Low NOx burners can achieve 40 to 60 % lower emission levels than traditional burners do. The carbon monoxide emissions of the Low NOx burners are also very low.

The high efficiency typical of Oilon burners applies to the Low NOx burners, too. With respect to the setting dimensions, the outer dimensions of the burner combustion head are the same as those of standard burners, so Low NOx burners are easy to install in place of traditional Oilon burners, without even electrical modifications. The burners are designed for H and E gases in gas category 2 (natural gas).



# Control panels and supply cabinets

This burner series incorporates separate control panels and power supply cabinets. The standard panels and cabinets are designed for voltages 3~400 V 50 Hz, control voltage 1~230 V 50 Hz. Enclosure class IP 40. Outer dimensions are 600 x 600 x 210 mm. When necessary, panels and cabinets can be built according to the customer's needs.

Type marking of the control panels: OK100  
Type marking of the supply cabinets: RK100

Fuel-specific type markings of the control panels:

Control panel for light fuel oil burner	OK100-KPMC0
Control panel for heavy fuel oil burner	OK100-RPMC0
Control panel for gas burner	OK100-GPMC1
Control panel for dual fuel burner light fuel oil/gas	OK100-GKPMC1
Control panel for dual fuel burner heavy fuel oil/gas	OK100-GRPMC1

## Control panel OK100

**Scope of delivery** Control panels include the following items:

• standard delivery      o optional

	OK100-KPMC0	OK100-RPMC0	OK100-GPMC1	OK100-GKPMC1	OK100-GRPMC1
Control unit LAL	•	•			
Control unit LFL			•	•	•
Capacity controller RWF-40	•	•	•	•	•
Capacity controller, other	o	o	o	o	o
Auxiliary relays	•	•	•	•	•
Burner control switch	•	•	•	•	•
Run hour counter for oil	•	•			
Run hour counter for gas			•	•	•
Failure reset button	•	•	•	•	•
Signal lamps	•	•	•	•	•
Preheater temperature controller CAL		•			•
Preheater operating switch		•			•
Remote start/stop	o	o	o	o	o
Capacity information for remote use (potentiometer with servomotor)	o	o	o	o	o
Potential-free alarms	o	o	o	o	o
Steam/water boiler automatics integrated into the control panel	o	o	o	o	o
O <sub>2</sub> display/alarm	o	o	o	o	o
Elevated IP class	o	o	o	o	o
Other voltage	o	o	o	o	o
Built according to the requirements of classification societies	o	o			
PLC control and/or electronic fuel/air ratio control	o	o	o	o	o
Flue gas damper control	o	o	o	o	o
Oil leakage alarm	o	o		o	o

## Supply cabinet RK100

**Scope of delivery** Supply cabinets include the following items:

	RK100
Main switch	•
Automatic circuit breakers	•
Contactor outputs	•
Thermal relays	•
Star-delta starter	o
Soft starter	o
Boiler automation power-current outputs	o



Control panel OK100



All-inclusive burner automatics: oxygen (O<sub>2</sub>)/pressure difference/cascade control



Supply cabinet RK100



# WiseDrive

## WiseDrive (WD), an electronic regulator for controlling the fuel/air ratio – an energy-efficient and environmentally friendly solution

Electronic fuel/air ratio control of the burner (optional) brings the benefits of lower flue gas emissions, decreased consumption of energy and improved technical characteristics of the burner, such as more accurate regulation.

### Examples of the WiseDrive's functions:

- Control sequences of the burner, conventional control unit deleted
- Fuel/air ratio control with dedicated servo motors, which can be set accurately for each control device
- Output regulator (PID) as standard, output regulation also by an external 4...20 mA signal
- When combusting gas, leak testing of the main gas valves carried out by the WiseDrive
- O<sub>2</sub> and fan motor RPM regulation according to the output
- Reading of the consumption signals from fuel gauges
- Can be connected with external plant automation via a ModBus
- 4 operating levels
- Input of parameters via a character display panel and an operating panel. Also comes with a graphical touch screen at extra cost.

## WiseDrive 200 + frequency converter + touch screen (unicode)

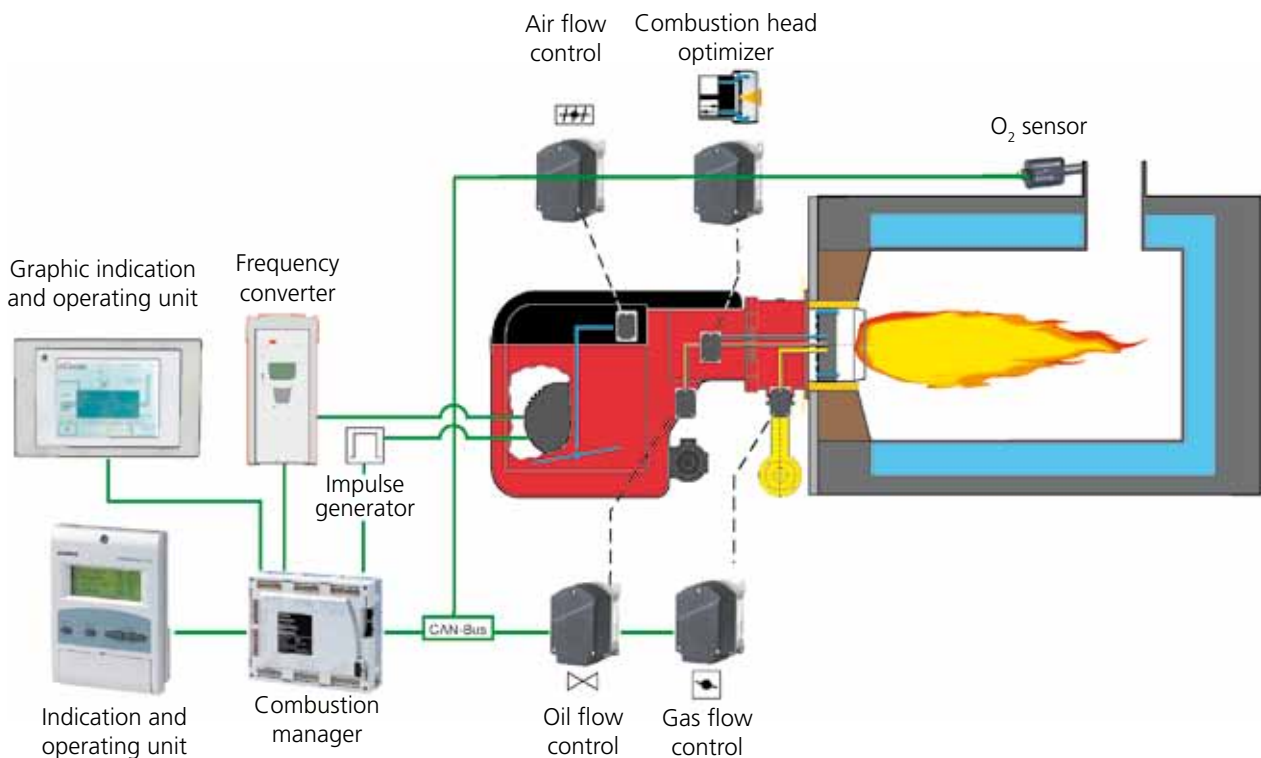

*Control sequences, fuel/air ratio and output regulation as well as leak testing of gas valves and much more in a single package.*

# Burner preheater

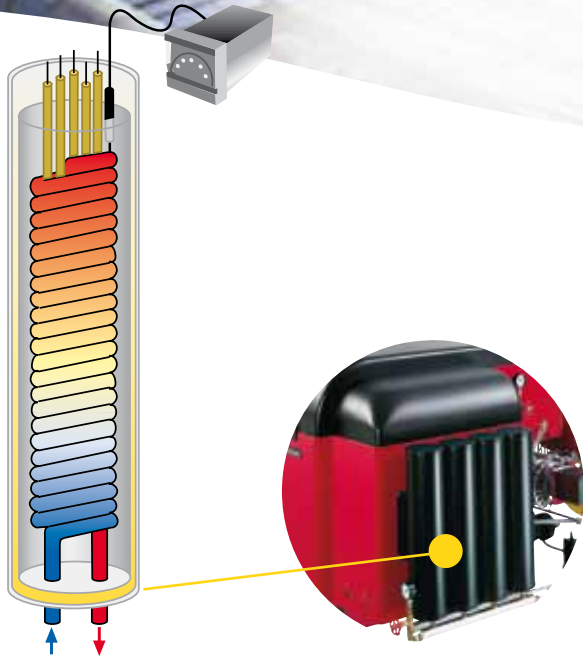

Oilon ML mass preheater keeps the oil temperature stable even if the incoming temperature fluctuates. On account of the construction and the electronic regulator, the temperature of the oil flowing to the nozzle remains stable. The burner may, depending on the capacity and model, have one or more 6-kW heater equipped with a safety device to guard against overheating. The electronic regulator has an integrated minimum temperature limiter as well; this prevents the burner from starting if the oil is too cold.

## Accurate temperature control guarantees good combustion

In burning heavy fuel oil, the right atomising viscosity of the oil is essential for good combustion and low combustion gas emissions. A prerequisite for stable atomising viscosity is that the oil temperature stays stable throughout the firing rate.

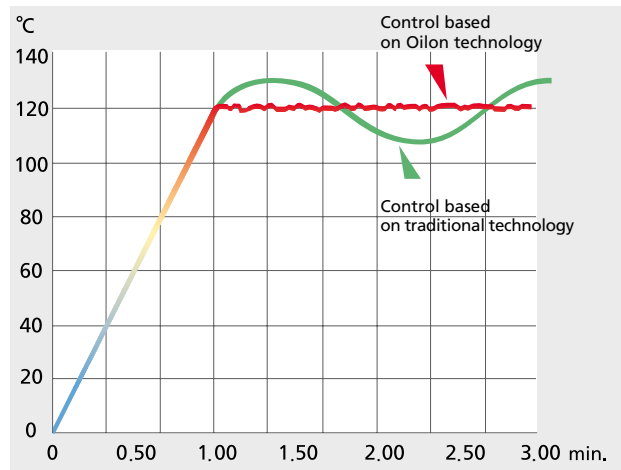

# Silencer

## Intake silencer, type MV 1

### Construction

The MV 1 silencer is made of steel plate lined with fireproof dampening wool. The silencer is connected to the burner's suction side via a screw connection. The silencer reduces the high-pitched sound produced by the air flow.



## Silencer, type MV 3

### Construction

The MV 3 silencer is made of steel plate lined with fireproof dampening wool. This wheel-equipped silencer isolates the burner from four sides. The MV 3 silencer reduces the sounds produced when the burner operates.



# Optimising combustion head pressure loss

The speed of the combustion air at the combustion head is controlled by moving the adjustment ring in the axial direction. When the adjustment ring is in the front position, the gap between the ring and the diffuser disc is small and therefore suitable for the minimum burner capacity. When the adjustment ring is in the rear position, the gap between the ring and the diffuser disc is large and therefore suitable for maximum capacity.

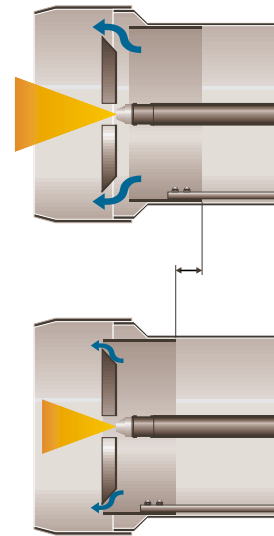
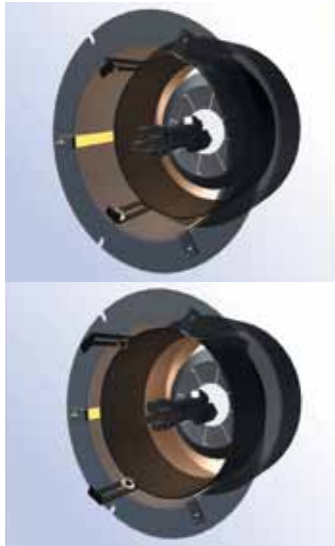

Automatic combustion head optimisation is available as an option for the modulating burners. With this, the movable combustion head adjustment ring is connected to the servomotor regulating the burner capacity. This way, the adjustment ring is always optimised for the required capacity. Furthermore, the adjustment range of the burner increases.

## Masonry figure

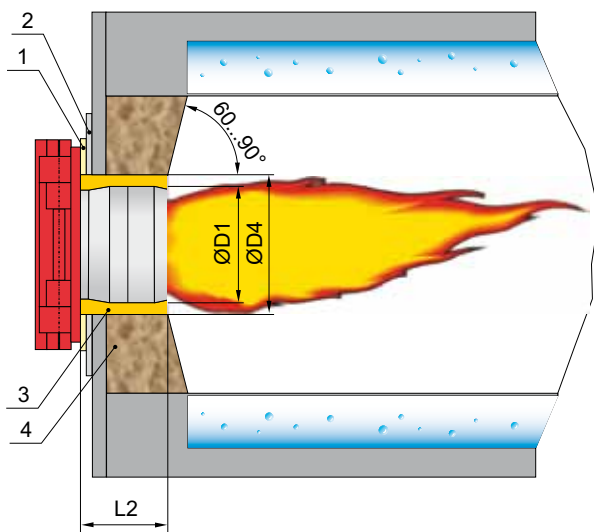

- 1 Gasket
- 2 Mounting panel
- 3 Ceramic wool or equivalent
- 4 Masonry
- ØD1, ØD4, L2 See burner dimension diagram

## Flame dimensions

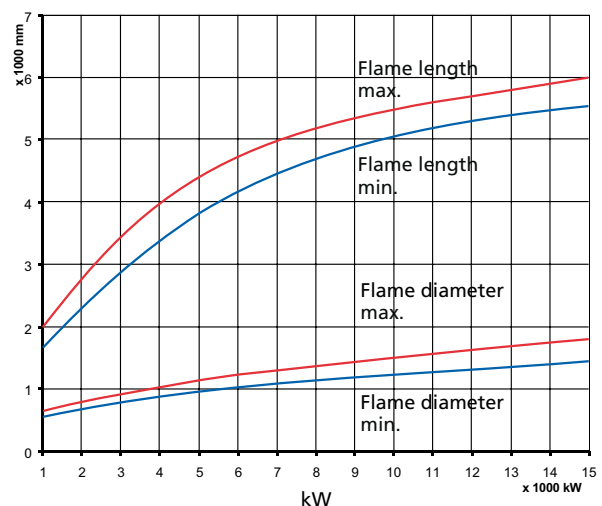

The dimensions apply for light oil and gas. For heavy oil, the dimensions used must be larger.



## Oil supply diagram for heavy fuel oil

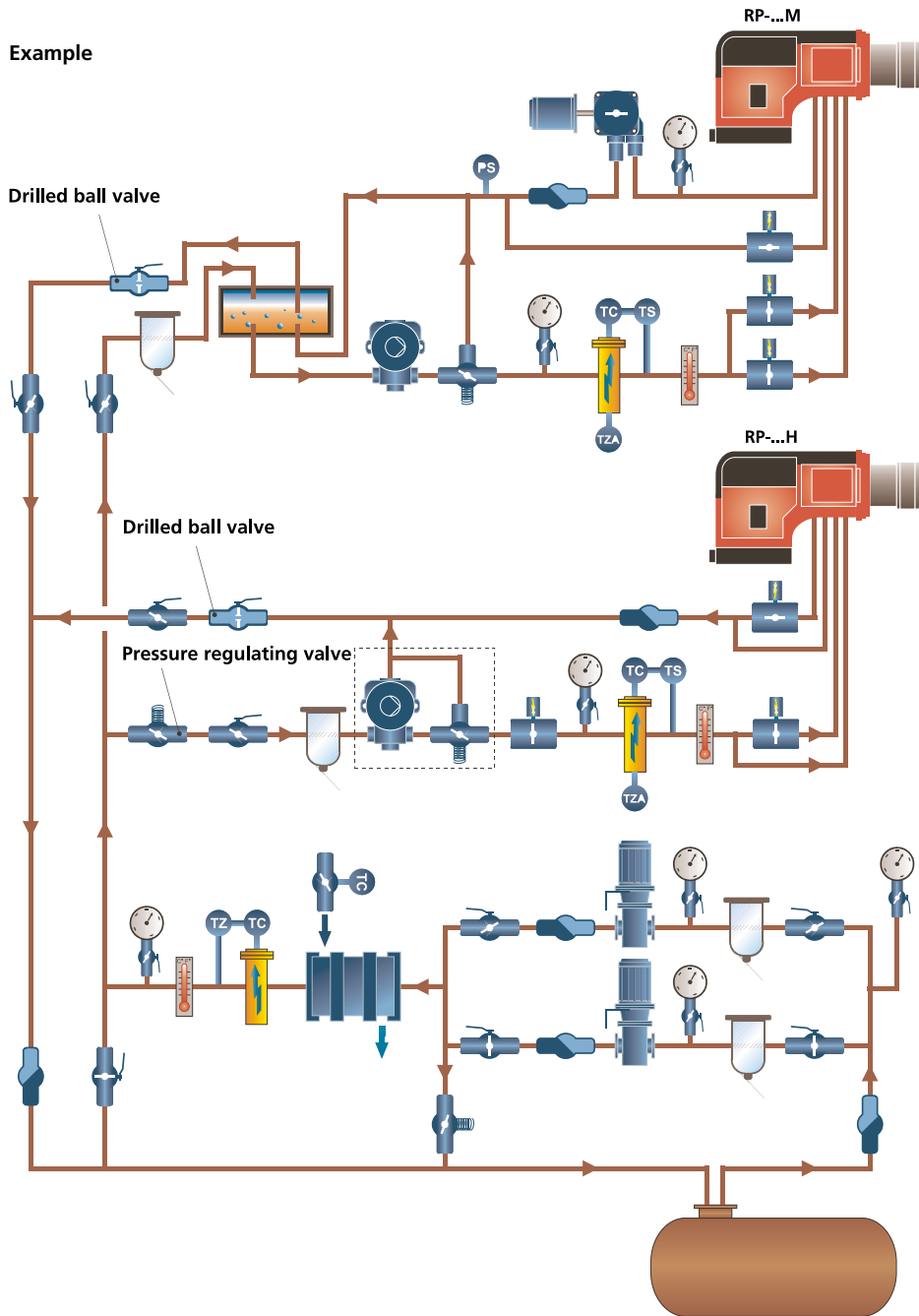

## Gas pressure control assembly

Example







*Oilon invests in product development and research. A modern product development centre meeting all European standards enables us to perform a wide range of burning tests and accurate oil and gas measurements.*



*We supply burners for ships according to classification societies, such as ABS, BV, CCS, DNV, GL, KR, LR, NKK, RINA, and RS classifications.*



*We participate in trade shows around the world every year.*

**OILON OY**

Metsä-Pietilänkatu 1  
P.O. Box 5  
FI-15801 Lahti, Finland  
Tel. +358 3 85 761  
Fax +358 3 857 6239  
info@oilon.com

**oilon**<sup>®</sup>  
www.oilon.com

