

Oil, Gas and Dual Fuel Burners

Burner series 130...150

250, 280

Group

3

Capacity
390-3500 kW

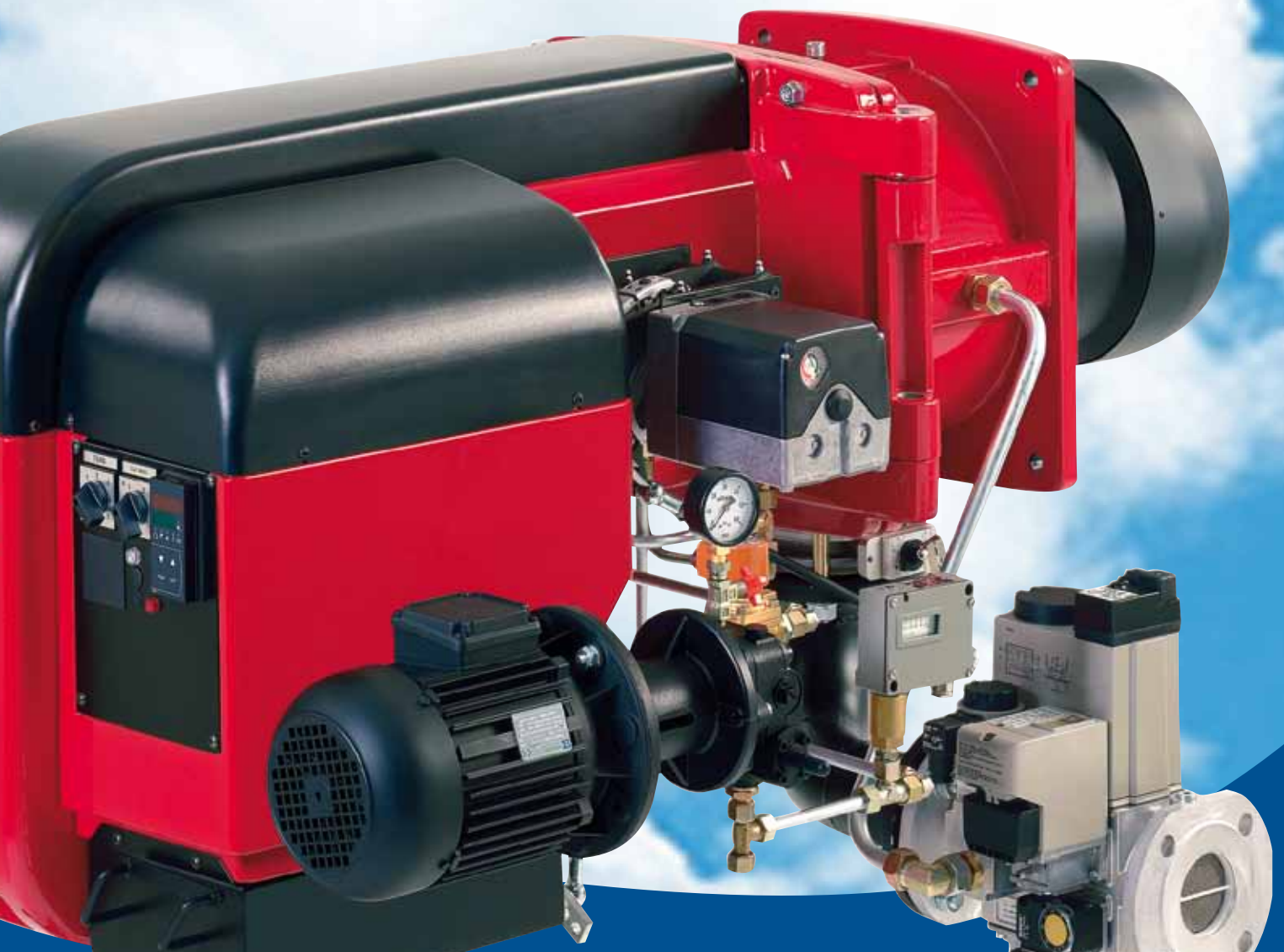

Table of contents

General	1
How to choose a burner	2
Light oil burners	
Technical data and dimensions	3-4
PI-diagrams	4
Capacity/back pressure graphs	5
Scope of delivery	6
Heavy oil burners	
Technical data and dimensions	7-8
PI-diagrams	8
Capacity/back pressure graphs	9
Scope of delivery	10
Gas burners	
Technical data and dimensions	11-12
PI-diagrams	12
Capacity/back pressure graphs	13
Scope of delivery	14
Dual fuel burners, light fuel oil/gas	
Technical data and dimensions	15-16
PI-diagrams	16
Capacity/back pressure graphs	17
Scope of delivery	18
Dual fuel burners, heavy fuel oil/gas	
Technical data and dimensions	19
PI-diagram	20
Capacity/back pressure graphs	20
Scope of delivery	21
Gas valve selection table	22
Gas elbow	22
Burner preheater	23
Silencer	24
WiseDrive – an electronic regulator for controlling the fuel/air ratio	24
Low NOx gas burner	25
Masonry figure	26
Flame dimensions	26
Servomotor	26
Oil supply diagram for heavy fuel oil	27
Gas pressure control assembly	27



Light oil burners

3 - 6



Heavy oil burners

7 - 10



Gas burners

11 - 14



Dual fuel burners, light fuel oil/gas

15 - 18



Dual fuel burners, heavy fuel oil/gas

19 - 21



Oil, Gas and Dual Fuel Burners

Burner series 130...150

250, 280



Oilon oil, gas, and dual fuel burners are fully automatic, safe, and reliable. The design and manufacturing of the burners is based on economy, safety, and service as well as environmental friendliness. Our gas burners comply with the EN 676 standard, oil burners with the EN 230 and EN 267 standards, and dual fuel burners with all of these. All burners are EU type tested. We also supply burners complying with various marine classification society requirements, such as ABS, BV, CCS, DNV, GL, KR, LR, NKK, RINA and RS.

Construction

All burner components are mounted directly on the burner housing. The aluminium alloy cast housing incorporates a three-phase motor that runs the fan and the oil pump. In dual fuel burners, the oil pump has its own three-phase motor. The motors' and preheaters' contactors and thermal relays are pre-mounted on the burner. The surface of the housing is finished with durable high-gloss paint. The housing is equipped with a hinged burner flange with a safety interlock switch, enabling the burner to be swung open to the left or right. The burner flange enables servicing of the combustion head, nozzles, and ignition electrodes without having to remove the burner itself. The stainless steel alloy combustion head and the diffuser disc can withstand temperatures of up to 1,200 °C. The combustion head is adjustable, thereby allowing optimal fuel mixing regardless of the firing rate. The burner houses a sight glass for flame observation. On the fan suction side there is an air damper that, together with the servomotor, automatically controls the amount of fuel and air based on demanded firing rate. A removable top cover allows for ease of electrical installation and burner service.

Installation and suitable applications

The burners are suitable for warm and hot water boilers, steam boilers, hot air generators, and various types of process heating. They are also designed to suit furnaces with high back pressure. The burners can be mounted in horizontal, vertical and upward-facing, or vertical and downward-facing orientations. Our burners are designed for operation in covered areas, max. +50 °C. Normal operating density altitude is 500 metres above sea level (other altitudes available upon request). The burner enclosure class is IP 20.

Fuels

Different fuels can be used depending on the burner model:

KP models:

- light fuel oil, viscosity 4 to 12 mm²/s, +20 °C

RP models:

- heavy fuel oil, viscosity max. 250 mm²/s, +50 °C
- heavy fuel oil, viscosity max. 450 mm²/s, +50 °C heating cartridge for pump and nozzle
- heavy fuel oil, viscosity max. 650 mm²/s, +50 °C heating cartridges as above + trace heating for oil piping

GP models:

- natural gas, 2nd family gases, groups H and E (equipment category I_{2R})

GKP and GRP dual fuel burners:

- fuel properties as above, natural gas/light fuel oil
- fuel properties as above, natural gas/heavy fuel oil

Burners using other fuels are available upon request. Gas and dual fuel burners meet the low NOx class requirements (EN 676 and EN267) in gas burning.

Capacity regulation methods

Option available, depending on the model:

- Two-stage, H
- Modulating, M

The two-stage burners are equipped with an air damper servomotor, run time of which is 5 seconds between capacity stages. The burners automatically operate in one- or two-stage mode according to the load. Modulating burners are equipped with a servomotor with a transition time of 30 sec/90°. The servomotor is connected to the oil regulator and compound regulator via an axle. A modulating burner operates regardless of the firing rate, on the basis of the load. The burners are adjusted on the basis of combustion gas analysis.

Oilon preheater guarantees accurate oil temperature control

RP and GRP models are equipped with oil shut-off valves, a filter, and an electric mass preheater. The preheater is controlled via an electronic regulator that keeps the oil temperature stable. A stable oil temperature makes it easier to obtain optimal combustion conditions. For our heavy oil burners, oil heated during the pre-purge phase flows to the nozzle through the preheater to ensure that the oil temperature is high enough during the ignition phase.

Gas equipment

Gas-related components of the gas and dual fuel burners comply with the EN 676 standard: two shut-off valves, pressure switches (min./max.), and an automatic valve leak tester. Other piping-related equipment is available upon request.

Oil piping

Mounted on the burner, three-stage burners with four solenoid valves (one main valve and one valve for each nozzle). Modulating burners have three solenoid valves. The oil regulator for the modulating burner is located on the nozzle return oil line. The oil filter is located on the suction side of the pump. The two oil hoses enable the burner to be hinged.

Flame monitoring

All models are equipped with automatic flame monitoring. In KP and RP models, flame monitoring is taken care of via a photocell; in GP, GKP, and GRP models, it is performed via a UV cell.

Control devices

The control automation (control unit) is integrated into the burner. The control unit handles all burner operation phases automatically. In the event of a burner failure, the unit stops the burner automatically. The modulating burners also incorporate a pre-mounted capacity controller.

Silencer

The sound level of the burners is low, but, if desired, they can be equipped with a separate silencer to make them even quieter.

Optimising combustion head pressure loss

For an additional charge, the modulating burners can be equipped with a system that optimises the combustion head pressure loss. The system reduces the amount of excess air and also improves combustion figures for partial burner loads.

We reserve the right to make technical alterations.

How to choose a burner

A. Procedure

- Establish relevant boiler and application information
 - boiler capacity and efficiency, or required burner capacity
 - furnace back pressure
 - fuel/fuels to be used
 - burner inlet fuel pressure
 - burner capacity regulation method
- Calculate the burner capacity. Burner capacity = boiler capacity / efficiency
 Example: boiler capacity of 2,500 kW, efficiency of 90 % → burner capacity = 2,500 kW / 0.9 = 2,780 kW
- Gas burners: Required gas flow [m³n/h] = (burner capacity [kW] x 3.6) / gas's calorific value [MJ/m³n].
 Example: required burner capacity = 2,780 kW → required gas flow = (2,780 kW x 3.6) / 35.8 MJ/m³n = 280 m³n/h, where 35.8 MJ/m³n is the calorific value of natural gas.
 Oil burners: Calculate the required oil flow [kg/h]. Required oil flow [kg/h] = (burner capacity [kW] x 3.6) / the oil's calorific value [MJ/kg]. Example: required burner capacity = 2,780 kW → required oil flow = (2,780 kW x 3.6) / 42.7 MJ/kg = 234 kg/h, where 42.7 MJ/kg is the calorific value of light oil.
- See relevant brochure for burner capacity/back pressure graphs: The graphs indicate the burner operating range. For example, the boiler back pressure with a burner capacity of 2,780 kW is 12 mbar. Looking at the adjoining graph, plot your burner capacity along the horizontal axis. On the vertical axis plot your boiler back-pressure. Where the two lines meet, defines the required burner type. The optimum burner is best chosen by ensuring that the plotted operating point is as close as possible to the right hand edge of the corresponding operating envelope. Note that different fuels and capacity regulation methods require separate graphs. The fuel calorific value is stated on the graphs.
- Gas and dual fuel burner valve selection : Select a suitable valve, using the gas valve selection table. Note that the values in the selection table apply when the furnace back pressure is 0 mbar. Therefore, you must subtract the furnace back pressure from the actual gas inlet pressure and choose the valve according to this value. The ratings shown in the table apply to natural gas.
 For example, using a gas inlet pressure of 70 mbar, a boiler back pressure of 12 mbar, a required burner capacity of 2,780 kW, the effective pressure will be 70 mbar - 12 mbar = 58 mbar. For the GP-280 M burner, for example, you should choose a valve allowing a minimum burner capacity of 2,780 kW with 58 mbar gas inlet pressure → in this case, valve DN 65.
- Check that the outer dimensions of the burner, especially those of the combustion head, are suitable for the application; the length of the combustion head should be such that, when mounted, the combustion head is even with the furnace wall or about 10 to 20 mm inside the furnace itself (see 'Masonry' figure).
- Check the flame dimensions in the flame dimension table. Please note that the flame must not come in to contact with the walls of the furnace.
- Accessory requirements must also be taken into consideration: gas pressure regulator, oil pumping unit, boiler thermostats/pressostats.

B. Equations and rules of thumb

- Burner capacity = boiler capacity / 0.9 (when boiler efficiency is 90 %)
- Steam boilers: 1 ton/h steam ≈ 700 kW boiler capacity
- Light oil: 1 kg/h ≈ 11.86 kW burner capacity with calorific value 42.7 MJ/kg
- Heavy oil: 1 kg/h ≈ 11.22 kW burner capacity with calorific value 40.5 MJ/kg
- Natural gas: 1 m³n/h ≈ 10 kW burner capacity with calorific value 35.84 MJ/m³n
- The amount of combustion air:
 - Gas burners: required amount of combustion air for each 10 kW of burner capacity is 12 to 13 m³/h.
 - Oil burners: required amount of combustion air for each kilo of oil burned [kg/h] is 13.5 m³/h.
- Oil pumping, filtering, and preheating unit (Oilon HotBox) is required with heavy fuel oil. The required minimum pump output [kg/h] can be calculated as follows:
 Required minimum output [kg/h] = (oil flow to be burned in kg/h + 150 to 200 kg/h) * 1.25 to 1.3, where the expression inside the parentheses indicates the preheated oil flow to each burner.

An example of burner selection

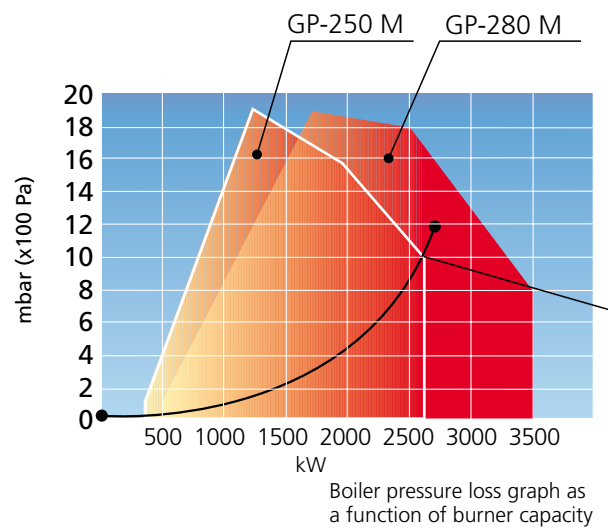

The max. capacity of a hot water boiler is 2,500 kW, efficiency 0.9, and the corresponding burner capacity 2,500 kW / 0.9 = 2,780 kW. The graph indicates that a suitable gas burner for this capacity is the GP-280 M, as the pressure loss value for the boiler is located inside the area for the GP-280 M burner on the capacity/back pressure graph. The GP-250 M can also be used for this application, provided that the full boiler capacity is not required. Remember to take efficiency into account when relating the boiler pressure loss information to the burner capacity/back pressure graph.



Light oil burners

KP-140 H... -150 H

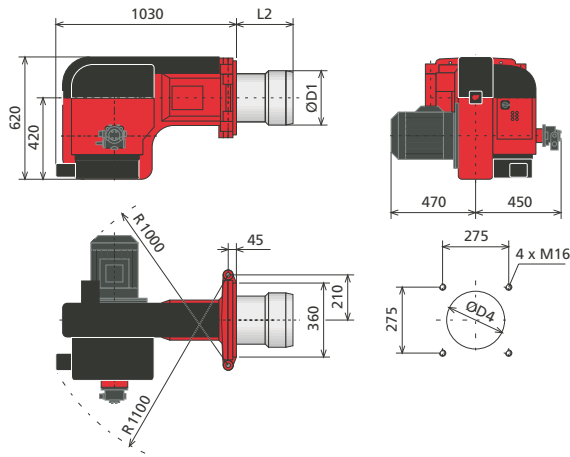

KP-130 M... -150 M

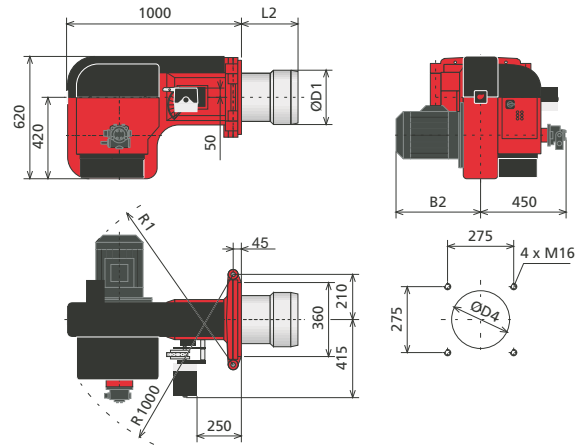

BURNER	L2	B2	Ø D1	Ø D4	R1
KP-140 H	220	470	240	270	1000
KP-150 H	230	470	270	300	1000
BURNER	L2	B2	Ø D1	Ø D4	R1
KP-130 M	200	430	200	230	980
KP-140 M	220	470	240	270	1000
KP-150 M	230	470	270	300	1000

KP-250 M, -280 M

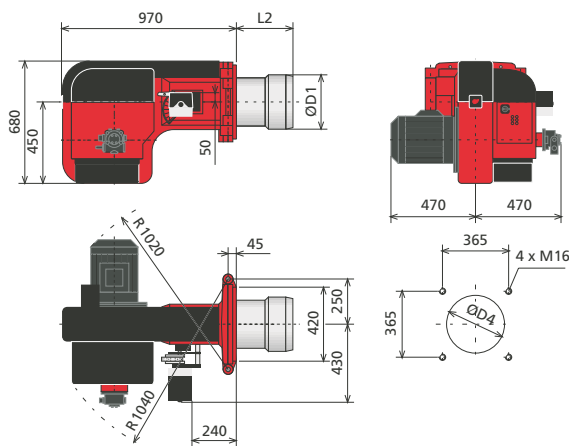

BURNER	L2	Ø D1	Ø D4
KP-250 M	300	270	300
KP-280 M	312	300	330

Light oil burners

TECHNICAL DATA

BURNER	KP-130 M	KP-140 H	KP-140 M	KP-150 H	KP-150 M
Capacity kg/h	32 - 126	47 - 200	47 - 200	85 - 210	56 - 240
kW	390 - 1500	550 - 2350	550 - 2350	1000 - 2490	660 - 2850
Burner motor 3~ 400 V 50 Hz					
Output kW	3,0	4,0	4,0	5,5	5,5
Current A	6,2	8,7	8,7	11,1	11,1
Speed rpm	2880	2900	2900	2910	2910
Control unit	LAL1.25	LAL1.25	LAL1.25	LAL1.25	LAL1.25
Oil hose connection					
- suction	R½"	R½"	R½"	R½"	R½"
- return	R½"	R½"	R½"	R½"	R½"
Oil pump	TA2	J7	TA2	TA2	TA2
Weight kg	114	107	118	113	128

BURNER	KP-250 M	KP-280 M
Capacity kg/h	55 - 220	76 - 295
kW	655 - 2600	900 - 3500
Burner motor 3~ 400 V 50Hz		
Output kW	7,5	7,5
Current A	14,7	14,7
Speed rpm	2855	2855
Control unit	LAL1.25	LAL1.25
Oil hose connection		
- suction	R¾"	R¾"
- return	R½"	R½"
Oil pump	TA3	TA3
Weight kg	146	150

PI-diagrams

KP-140 H, -150 H

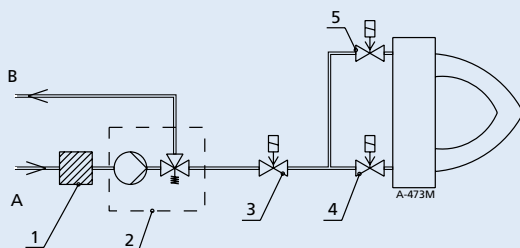

- 1 Oil filter
- 2 Oil pump, plugged
- 3 Solenoid valve, NC
- 4 Solenoid valve, NC
- 5 Solenoid valve, NC
- A Oil, inlet
- B Oil, return

KP-130 M...-150 M, -250 M, -280 M

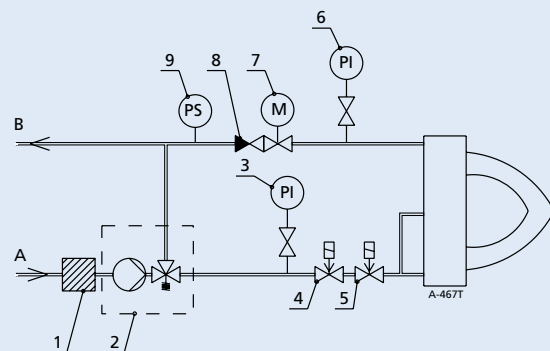

- 1 Oil filter
- 2 Oil pump, plugged
- 3 Pressure gauge, gauge valve
- 4 Solenoid valve, NC
- 5 Solenoid valve, NC
- 6 Pressure gauge, gauge valve
- 7 Oil regulator/servomotor
- 8 Non-return valve
- 9 Pressure switch, max.
- A Oil, inlet
- B Oil, return

Light oil burners

Capacity/back pressure graphs

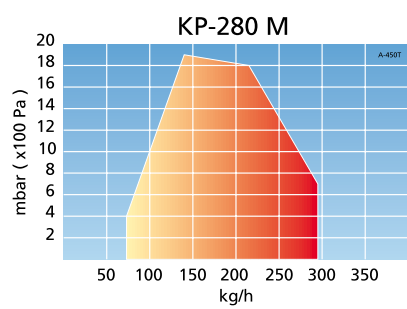
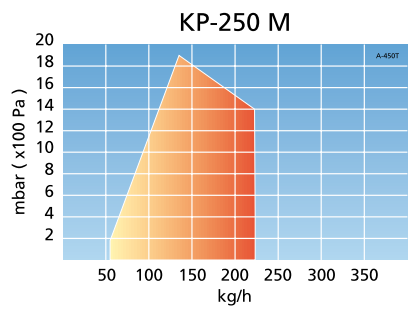
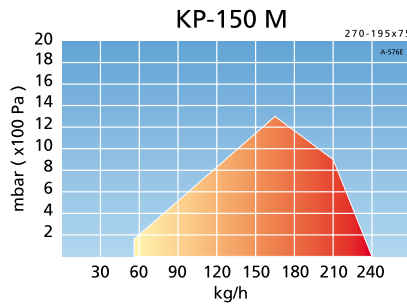
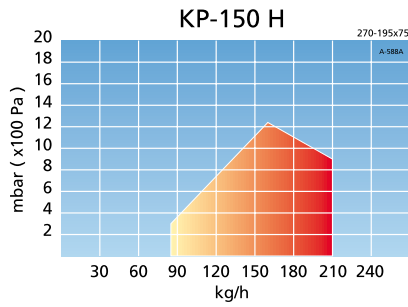
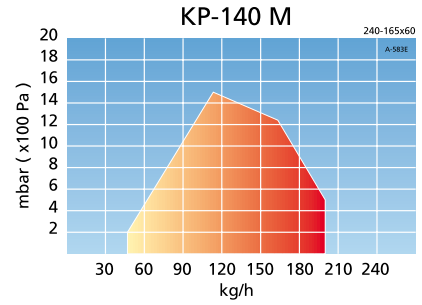
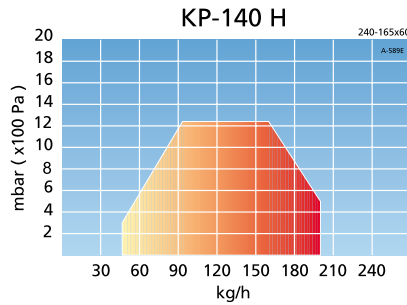
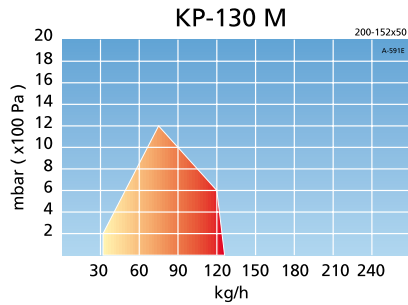

Light fuel oil: 1 kg/h = 11.86 kW

Light oil burners

Scope of delivery

Burners include following equipment:

	KP-140,150 H	KP-130...150 M	KP- 250, 280 M
Hinge flange with limit switch	•	•	•
Burner flange gasket	•	•	•
Oil nozzle/nozzles	•	•	•
Solenoid valves for oil	•	•	•
Oil pump with pressure regulating valve	•	•	•
Non-return valve		•	•
2 pressure gauges for oil		•	•
Pressure switch for return oil		•	•
Deaerator		o	o
2 oil hoses, length 2000 mm	•	•	•
Oil filter	•	•	•
Pressure gauge for control of inlet oil	o	o	o
Pressure switch for control of inlet oil	o	o	o
Compound regulator for regulation of air/oil ratio incl.: - oil regulator - servomotor		•	•
Potentiometer fitted in servomotor	o	o	o
Differential air pressure switch	o	o	o
Ignition transformer	•	•	•
Ignition cables and electrodes	•	•	•
Flame sensor	•	•	•
Inbuilt combustion air fan with direct-driven electric motor	•	•	•
Air dampers	•	•	•
Separate servomotor for air dampers	•		
Pressure gauge for fan pressure	o	o	o
Control unit	•	•	•
Capacity controller	o	•	•
Motor contactors and thermal relays	•	•	•
Operating switches	•	•	•
Manual	•	•	•

• standard delivery

o option



Heavy oil burners

RP-130 H... -150 H

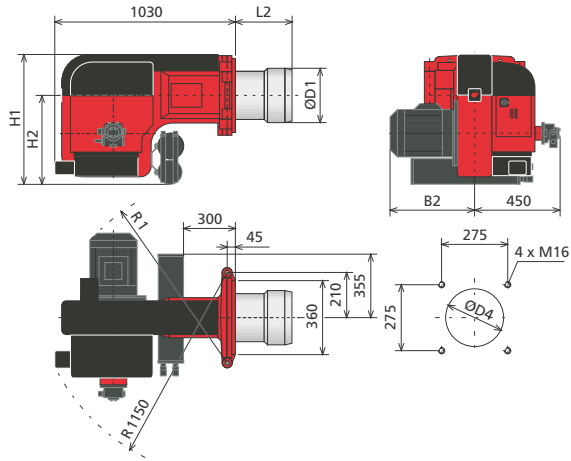

RP-130 M... -150 M

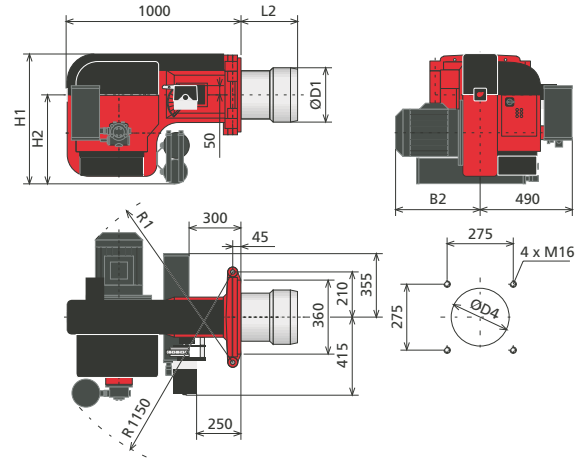

BURNER	L2	H1	H2	B2	Ø D1	Ø D4	R1
RP-130 H	200	620	420	430	200	230	980
RP-140 H	220	620	420	470	240	270	1000
RP-150 H	230	750	500	470	270	300	1000

BURNER	L2	H1	H2	B2	Ø D1	Ø D4	R1
RP-130 M	200	620	420	430	200	230	980
RP-140 M	220	620	420	470	240	270	1000
RP-150 M	230	750	500	470	270	300	1000

RP-250 M, -280 M

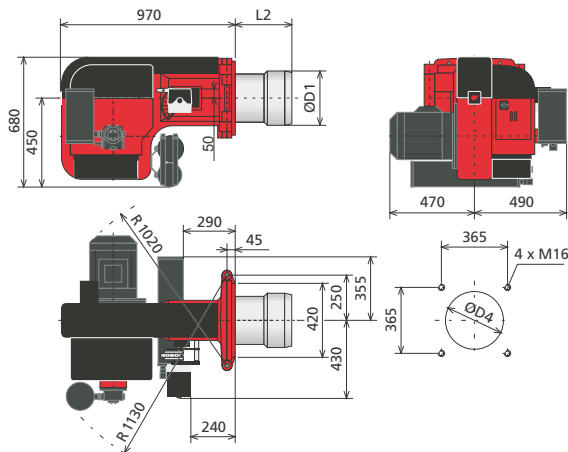

BURNER	L2	Ø D1	Ø D4
RP-250 M	300	270	300
RP-280 M	312	300	330

Heavy oil burners

TECHNICAL DATA

BURNER	RP-130 H	RP-130 M	RP-140 H	RP-140 M	RP-150 H	RP-150 M
Capacity kg/h kW	44 - 121 500 - 1370	34 - 121 390 - 1370	60 - 180 680 - 2040	50 - 180 560 - 2040	86 - 210 975 - 2400	60 - 240 680 - 2700
Burner motor 3~ 400 V 50 Hz Output kW Current A Speed rpm	3,0 6,2 2880	3,0 6,2 2880	4,0 8,7 2900	4,0 8,7 2900	5,5 11,1 2910	5,5 11,1 2910
Control unit	LAL1.25	LAL1.25	LAL1.25	LAL1.25	LAL1.25	LAL1.25
Oil hose connection - suction - return	R½" R½"	R½" R½"	R½" R½"	R½" R½"	R½" R½"	R½" R½"
Oil pump	E7	TA2	E7	TA2	TA2	TA2
Preheater 3~ 400 V 50 Hz Capacity kW	6	6	6	6	12	12
Weight kg	115	140	121	139	150	167

BURNER	RP-250 M	RP-280 M
Capacity kg/h kW	58 - 230 650 - 2600	80 - 308 900 - 3500
Burner motor 3~ 400 V 50 Hz Output kW Current A Speed rpm	7,5 14,7 2855	7,5 14,7 2855
Control unit	LAL1.25	LAL1.25
Oil hose connection - suction - return	R¾" R½"	R¾" R½"
Oil pump	TA3	TA3
Preheater 3~ 400 V 50 Hz Capacity kW	12	12
Weight kg	195	196

PI-diagrams

RP-130 H...-150 H

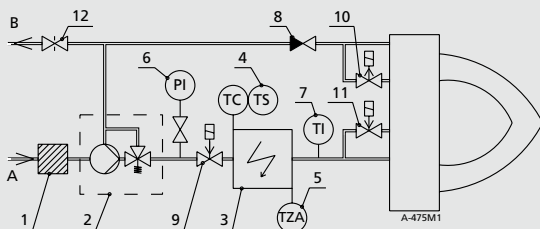

- 1 Oil filter
- 2 Oil pump, without plug
- 3 Preheater
- 4 Temperature regulation/ lower limit
- 5 Limit thermostat
- 6 Pressure gauge, gauge valve
- 7 Thermometer
- 8 Non-return valve, throttle plug \varnothing 1.2 mm
- 9 Solenoid valve, NC
- 10 Solenoid valve, NO
- 11 Solenoid valve, NC
- 12 Drilled ball valve
- A Oil, inlet
- B Oil, return

RP-130 M...-150 M, -250 M, -280 M

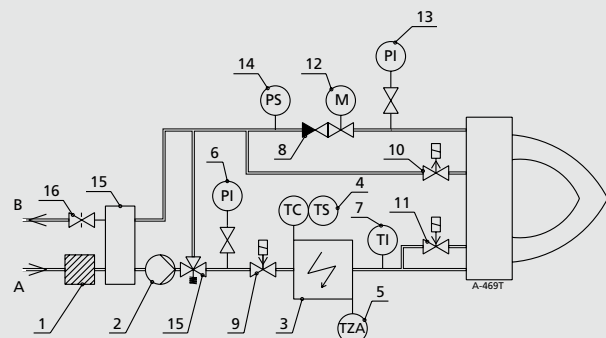

- 1 Oil filter
- 2 Oil pump, with plug
- 3 Preheater
- 4 Temperature regulation/ lower limit
- 5 Limit thermostat
- 6 Pressure gauge, gauge valve
- 7 Thermometer
- 8 Non-return valve
- 9 Solenoid valve, NC
- 10 Solenoid valve, NO
- 11 Solenoid valve, NC
- 12 Oil regulator/servomotor
- 13 Pressure gauge, gauge valve
- 14 Pressure switch, max.
- 15 Deaerator
- 16 Drilled ball valve
- A Oil, inlet
- B Oil, return

Heavy oil burners

Capacity/back pressure graphs

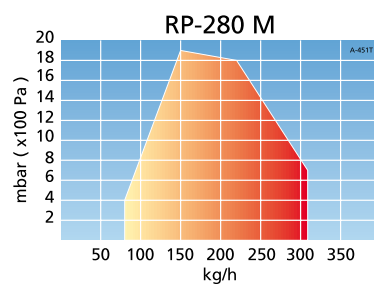
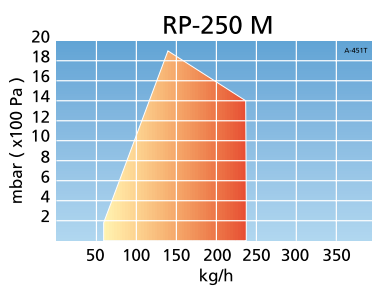
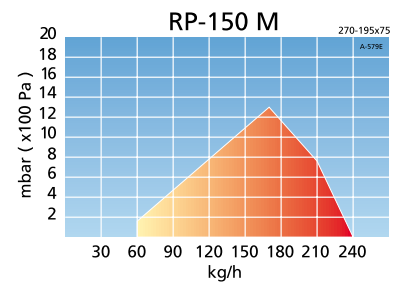
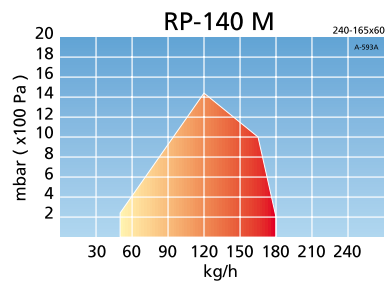
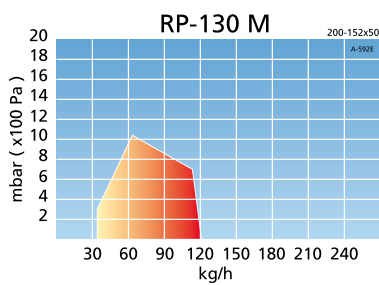
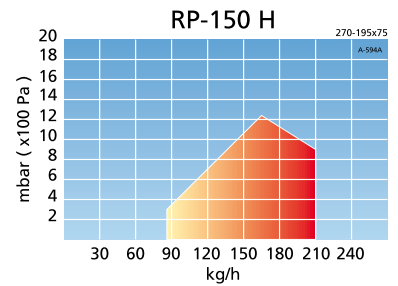
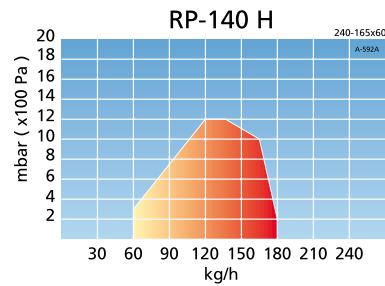
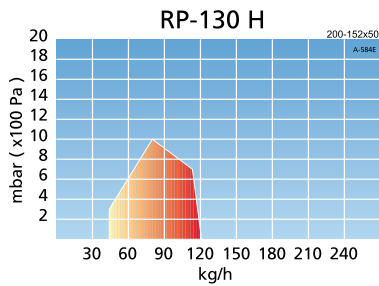

Heavy fuel oil: 1 kg/h = 11.22 kW

Heavy oil burners

Scope of delivery

Burners include following equipment:

	RP-130 H...150 H	RP-130...150 M	RP- 250, 280 M
Hinge flange with limit switch	•	•	•
Burner flange gasket	•	•	•
Oil nozzle/nozzles	•	•	•
Heating cartridge for oil nozzle	o	o	o
Solenoid valves for oil	•	•	•
Heating cartridge for solenoid valves	•	•	•
Oil pump with pressure regulating valve	•	•	•
Heating cartridge for oil pump	o	o	o
Non-return valve		•	•
2 oil pressure gauges		•	•
Thermometer	•	•	•
Pressure switch for return oil		•	•
Deaerator		•	•
Electric preheater incl.: - limit thermostat - electronic temperature controller - temperature sensor	•	•	•
2 oil hoses, length 2000 mm	•	•	•
Electric tracing cables for burner oil pipes	o	o	o
Electric tracing cables for oil hoses	o	o	o
Oil filter	•	•	•
Pressure gauge for control of inlet oil	o	o	o
Pressure switch for control of inlet oil	o	o	o
Compound regulator for regulation of air/oil ratio incl.: - oil regulator - servomotor		•	•
Potentiometer fitted in servomotor	o	o	o
Differential air pressure switch	o	o	o
Ignition transformer	•	•	•
Ignition cables and electrodes	•	•	•
Flame sensor	•	•	•
Inbuilt combustion air fan with direct-driven electric motor	•	•	•
Air dampers	•	•	•
Separate servomotor for air dampers	•		
Pressure gauge for fan pressure	o	o	o
Control unit	•	•	•
Capacity controller	o	•	•
Motor contactors and thermal relays	•	•	•
Preheater contactors	•	•	•
Operating switches	•	•	•
Manual	•	•	•

• standard delivery

o option

Gas burners

GP-140 H... -150 H

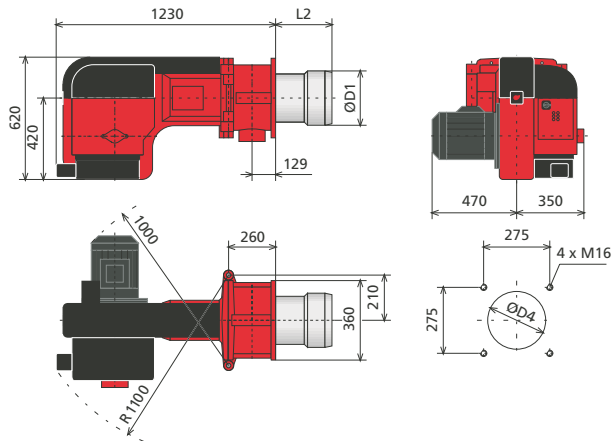

GP-130 M... -150 M

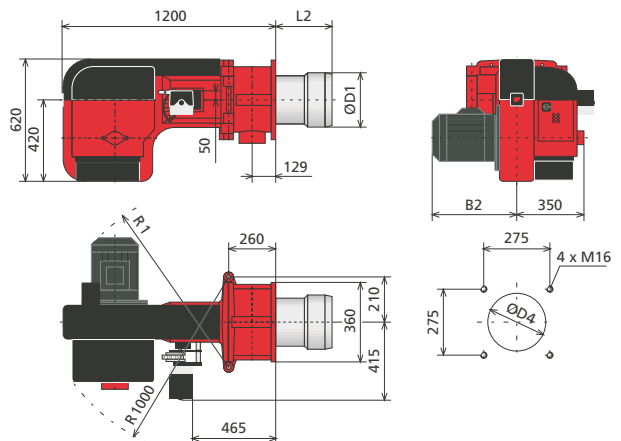

BURNER	L2	Ø D1	Ø D4	R1
GP-140 H	220	240	270	1000
GP-150 H	230	270	300	1000

BURNER	L2	B2	Ø D1	Ø D4	R1
GP-130 M	200	430	200	230	980
GP-140 M	220	470	240	270	1000
GP-150 M	230	470	270	300	1000

GP-250 M, -280 M

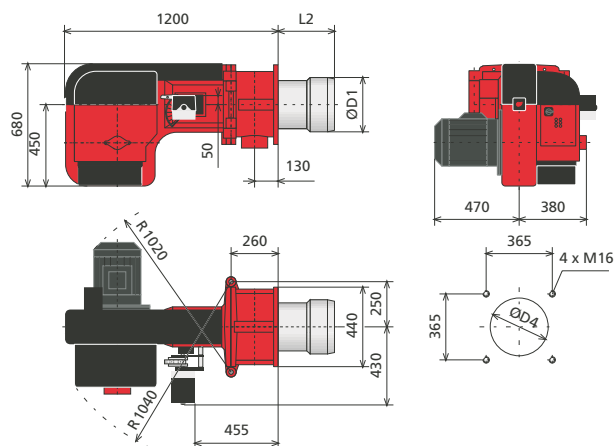

BURNER	L2	Ø D1	Ø D4
GP-250 M	295	270	300
GP-280 M	307	300	330

Gas burners

TECHNICAL DATA

BURNER	GP-130 M	GP-140 H	GP-140 M	GP-150 H	GP-150 M
Capacity kW	390 - 1500	410 - 2350	410 - 2350	450 - 2700	450 - 2700
Burner motor 3~ 400 V 50 Hz					
Output kW	3,0	4,0	4,0	5,5	5,5
Current A	6,2	8,7	8,7	11,1	11,1
Speed rpm	2880	2900	2900	2910	2910
Control unit	LFL1.322	LFL1.322	LFL1.322	LFL1.322	LFL1.322
Weight kg	115	110	121	125	130

BURNER	GP-250 M	GP-280 M
Capacity kW	370 - 2600	500 - 3500
Burner motor 3~ 400 V 50 Hz		
Output kW	5,5	7,5
Current A	10,9	14,7
Speed rpm	2855	2855
Control unit	LFL1.322	LFL1.322
Weight kg	160	210

PI-diagrams

GP-140 H, -150 H

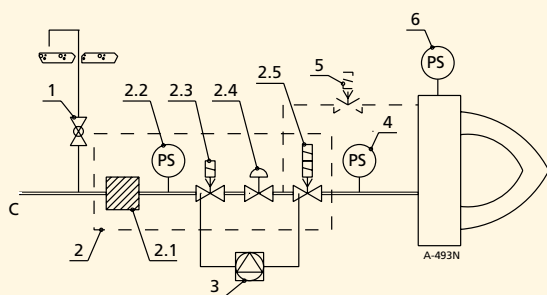

- 1 Ball valve, blow-off
- 2 Gas valve
- 2.1 Gas filter
- 2.2 Pressure switch, min.
- 2.3 Gas valve 1
- 2.4 Pressure regulator
- 2.5 Gas valve 2, two-stage
- 3 Valve leak tester
- 4 Pressure switch, max.
- 5 Solenoid valve, NC, ignition gas *)
- 6 Differential air pressure switch

*) only on request

GP-130 M...-150 M, GP-250 M, -280 M

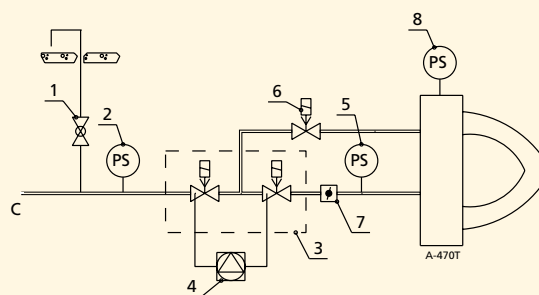

- 1 Ball valve, blow-off
- 2 Pressure switch, min.
- 3 Double solenoid valve
- 4 Valve leak tester
- 5 Pressure switch, max.
- 6 Solenoid valve, NC, ignition gas *)
- 7 Gas butterfly valve
- 8 Differential air pressure switch

*) on 130...150 burners only on request
on 250, 280 burners as standard

Gas burners

Capacity/back pressure graphs

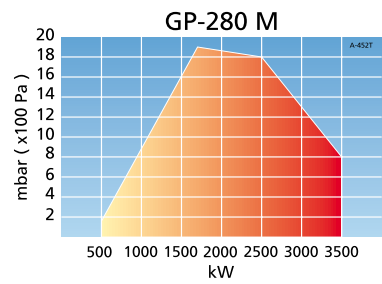
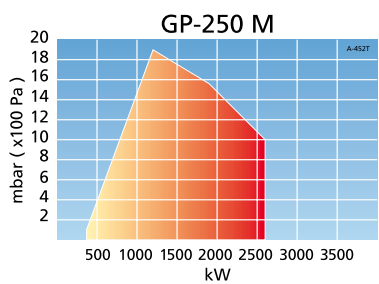
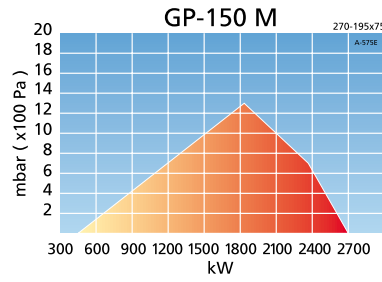
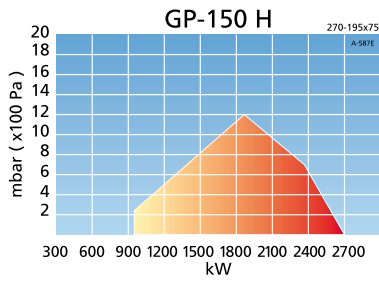
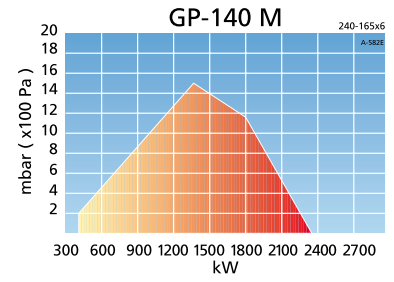
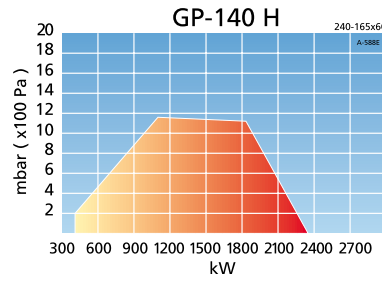
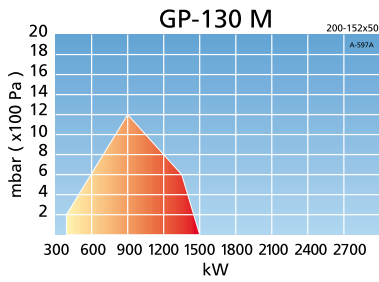

Natural gas: gases of 2nd family, groups H and E
(equipment category I_{2R})

Gas burners

Scope of delivery

Burners include following equipment:

	GP-140 H, 150 H	GP-130 M...150 M	GP-250 M, 280 M
Hinge flange with limit switch	•	•	•
Burner flange gasket	•	•	•
Compound regulator for regulation of air/gas ratio incl.: - servomotor		•	•
Potentiometer fitted in servomotor	o	o	o
Gas nozzle	•	•	•
Pressure gauge for measuring the pressure in gas nozzle	o	o	o
Gas butterfly valve		•	•
Max. gas pressure switch	•	•	•
Differential air pressure switch	•	•	•
Ignition transformer	•	•	•
Ignition cables and electrodes	•	•	•
Flame sensor	•	•	•
Inbuilt combustion air fan with direct-driven electric motor	•	•	•
Air dampers	•	•	•
Separate servomotor for air dampers	•		
Pressure gauge for fan pressure	o	o	o
Control unit	•	•	•
Capacity controller	o	•	•
Motor contactors and thermal relays	•	•	•
Operating switches	•	•	•
Elbow 90°	•	•	•
Double solenoid valve for gas incl.: - gas pressure switch, min. - 2 gas valves - automatic valve proving system - ball valve, blow-off (loose)		•	•
Gas train incl.: - gas pressure switch, min. - main gas valve - gas valve, two-stage - pressure regulator - automatic valve proving system - filter - ball valve, blow-off (loose)	•		
Solenoid valve for ignition gas			•
Manual	•	•	•

• standard delivery

o option

Dual fuel burners, light fuel oil/gas

GKP-130 H... -150 H

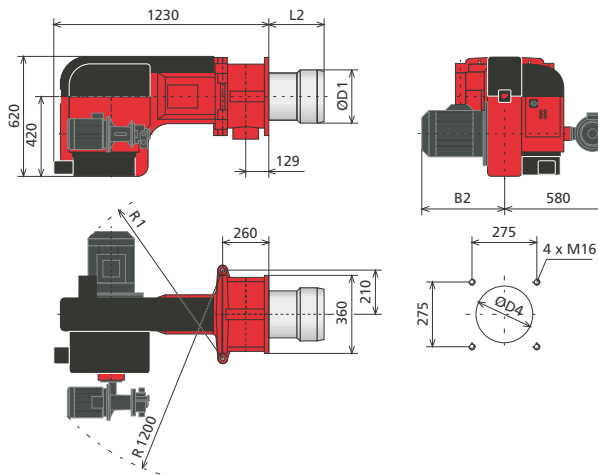

GKP-130 M... -150 M

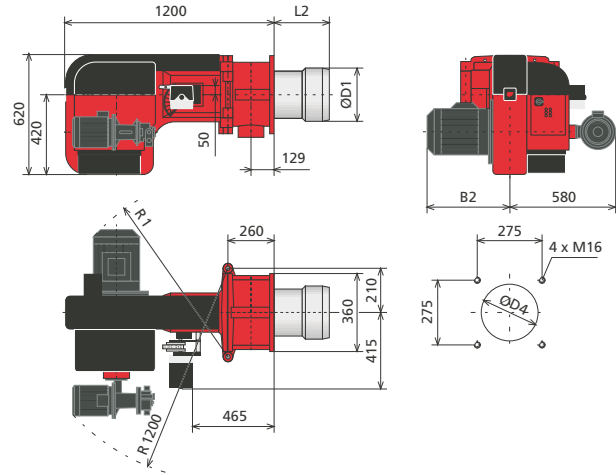

BURNER	L2	B2	Ø D1	Ø D4	R1
GKP-130 H	200	430	200	230	980
GKP-140 H	220	470	240	270	1000
GKP-150 H	230	470	270	300	1000

BURNER	L2	B2	Ø D1	Ø D4	R1
GKP-130 M	200	430	200	230	980
GKP-140 M	220	470	240	270	1000
GKP-150 M	230	470	270	300	1000

GKP-250 M, -280 M

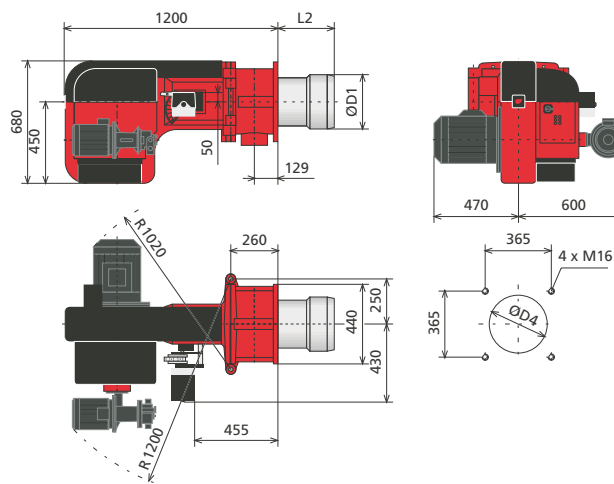

BURNER	L2	Ø D1	Ø D4
GKP-250 M	295	270	300
GKP-280 M	307	300	330

Dual fuel burners, light fuel oil/gas

TECHNICAL DATA

BURNER	GKP-130 H	GKP-130 M	GKP-140 H	GKP-140 M	GKP-150 H	GKP-150 M
Capacity oil, kg/h oil, kW gas, kW	32 - 126 390 - 1500 390 - 1500	32 - 126 390 - 1500 390 - 1500	47 - 200 550 - 2350 550 - 2350	47 - 200 550 - 2350 410 - 2350	85 - 210 1000 - 2490 1000 - 2490	56 - 227 660 - 2700 450 - 2700
Fan motor 3~ 400 V 50 Hz Output kW Current A Speed rpm	3,0 6,2 2880	3,0 6,2 2880	4,0 8,7 2900	4,0 8,7 2900	5,5 11,1 2910	5,5 11,1 2910
Control unit	LFL1.322	LFL1.322	LFL1.322	LFL1.322	LFL1.322	LFL1.322
Oil hose connection - suction - return	R½" R½"	R½" R½"	R½" R½"	R½" R½"	R½" R½"	R½" R½"
Oil pump - Motor 3~ 400 V 50 Hz Output kW Current A Speed rpm	J7 1,5 3,3 2870	TA2 1,5 3,3 2870	J7 1,5 3,3 2870	TA2 1,5 3,3 2870	TA2 1,5 3,3 2870	TA2 1,5 3,3 2870
Weight kg	121	144	129	162	147	164

BURNER	GKP-250 M	GKP-280 M
Capacity oil, kg/h oil, kW gas, kW	55 - 220 650 - 2600 370 - 2600	76 - 295 900 - 3500 500 - 3500
Fan motor 3~ 400 V 50 Hz Output kW Current A Speed rpm	5,5 10,9 2855	7,5 14,7 2855
Control unit	LFL1.322	LFL1.322
Oil hose connection - suction - return	R¾" R½"	R¾" R½"
Oil pump - Motor 3~ 400 V 50 Hz Output kW Current A Speed rpm	TA3 1,5 3,3 2870	TA3 1,5 3,3 2870
Weight kg	270	278

PI-diagrams

GKP-130 H...-150 H

- | | |
|---------------------------------------|------------------------------------|
| 1 Ball valve, blow-off | 6 Differential air pressure switch |
| 2 Gas valve | 7 Oil filter |
| 2.1 Gas filter | 8 Oil pump, with plug |
| 2.2 Pressure switch, min. | 9 Solenoid valve, NC |
| 2.3 Gas valve 1 | 10 Solenoid valve, NC |
| 2.4 Pressure regulator | 11 Solenoid valve, NC |
| 2.5 Gas valve 2, two-stage | |
| 3 Valve leak tester | A Oil, inlet |
| 4 Pressure switch for gas, max. | B Oil, return |
| 5 Solenoid valve, NC, ignition gas *) | C Gas |
| | *) only on request |

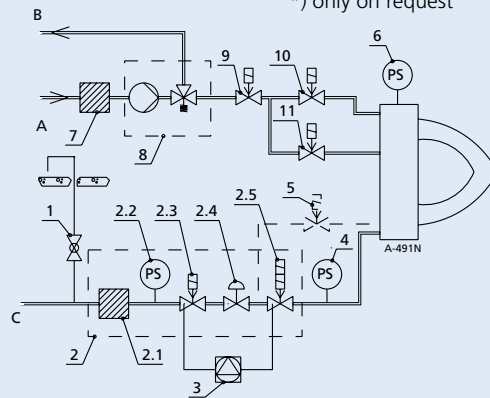

GKP-130 M...-150 M, -250 M, -280 M

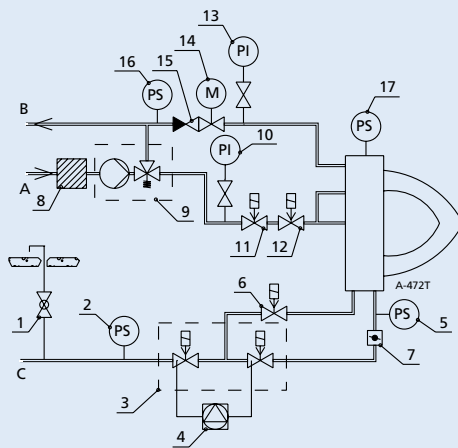

- | | |
|---------------------------------------|-------------------------------------|
| 1 Ball valve, blow-off | 12 Solenoid valve, NC |
| 2 Pressure switch, min. | 13 Pressure gauge, gauge valve |
| 3 Double solenoid valve | 14 Oil regulator/servomotor |
| 4 Valve leak tester | 15 Non-return valve |
| 5 Pressure switch, gas, max. | 16 Pressure switch for oil, max. |
| 6 Solenoid valve, NC, ignition gas *) | 17 Differential air pressure switch |
| 7 Gas butterfly valve | |
| 8 Oil filter | A Oil, inlet |
| 9 Oil pump, with plug | B Oil, return |
| 10 Pressure gauge, gauge valve | C Gas |
| 11 Solenoid valve, NC | |

*) on 130...150 burners only on request
on 250, 280 burners as standard

Dual fuel burners, light fuel oil/gas

Capacity/back pressure graphs

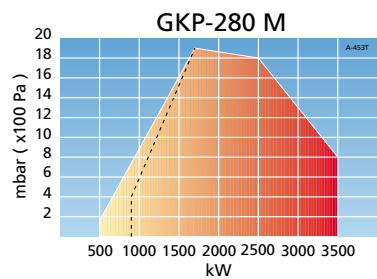
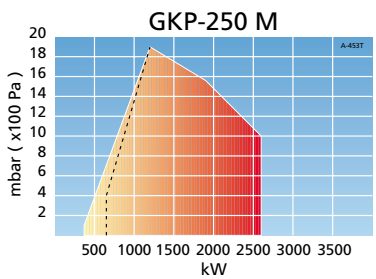
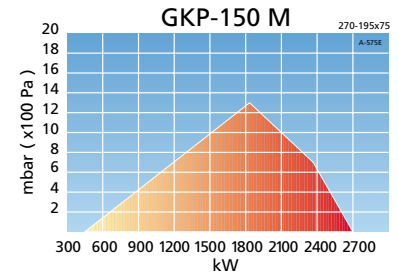
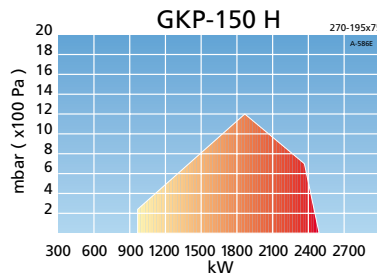
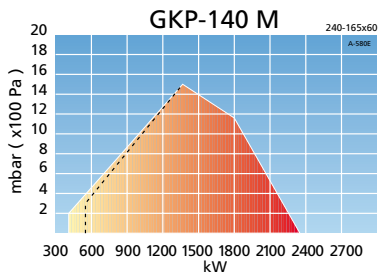
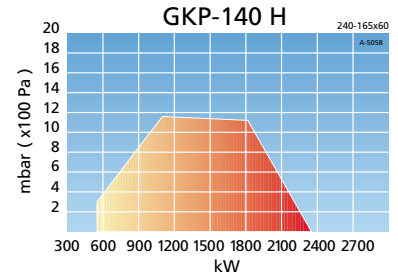
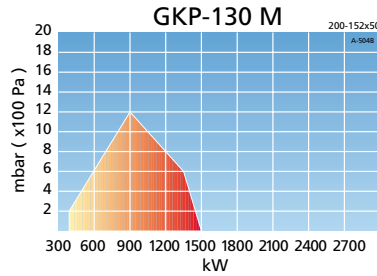
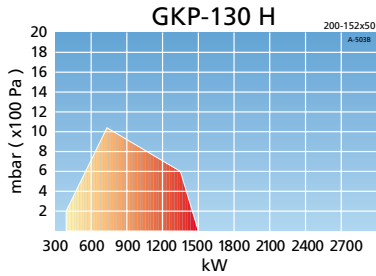

Natural gas: gases of 2nd family, groups H and E
(equipment category I_{2R})
Light fuel oil: 1 kg/h = 11.86 kW

Dual fuel burners, light fuel oil/gas

Scope of delivery

Burners include following equipment:

	GKP-130 H...150 H	GKP-130 M...150 M	GKP-250 M, -280 M
Hinge flange with limit switch	•	•	•
Burner flange gasket	•	•	•
Oil nozzle/nozzles	•	•	•
Solenoid valves for oil	•	•	•
Oil pump with pressure regulating valve	•	•	•
Separate motor for oil pump	•	•	•
Non-return valve		•	•
2 pressure gauges for oil		•	•
Pressure switch for return oil		•	•
Deaerator		o	o
2 oil hoses, length 2000 mm	•	•	•
Oil filter	•	•	•
Pressure gauge for control of inlet oil	o	o	o
Pressure switch for control of inlet oil	o	o	o
Compound regulator for regulation of air/gas/oil ratio incl.: - oil regulator - servomotor		•	•
Potentiometer fitted in servomotor	o	o	o
Gas nozzle	•	•	•
Pressure gauge for measuring the pressure in gas nozzle	o	o	o
Gas butterfly valve		•	•
Gas pressure switch, max.	•	•	•
Differential air pressure switch	•	•	•
Ignition transformer	•	•	•
Ignition cables and electrodes	•	•	•
Flame sensor	•	•	•
Inbuilt combustion air fan with direct-driven electric motor	•	•	•
Air dampers	•	•	•
Separate servomotor for air dampers	•		
Pressure gauge for fan pressure	o	o	o
Capacity controller	o	•	•
Motor contactors and thermal relays	•	•	•
Preheater contactors			
Operating switches	•	•	•
Elbow 90°	•	•	•
Double solenoid valve for gas incl.: - pressure switch for gas, min. - 2 gas valves - automatic valve proving system - ball valve, blow-off (loose)		•	•
Gas train incl.: - gas pressure switch, min. - main gas valve - gas valve, two-stage - pressure regulator - automatic valve proving system - filter - ball valve, blow-off (loose)	•		
Solenoid valve for ignition gas			•
Manual	•	•	•

• standard delivery o option

Dual fuel burners, heavy fuel oil/gas

GRP-130 M... -150 M

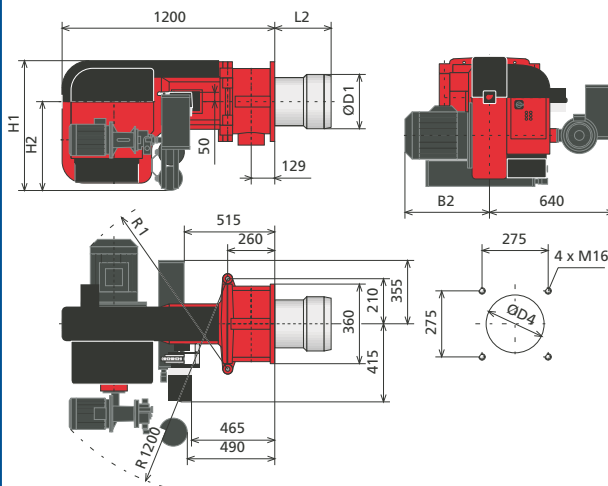

GRP-250 M, -280 M

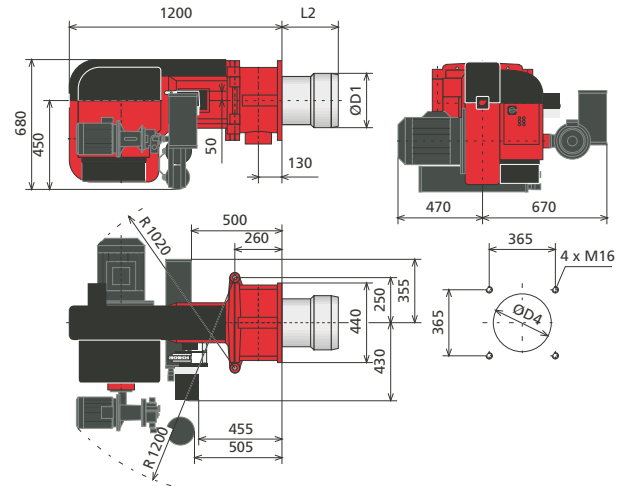

BURNER	L2	L4	H1	H2	B2	Ø D1	Ø D4	R1
GRP-130 M	200	450	610	420	430	200	230	980
GRP-140 M	220	450	610	420	470	240	270	1000
GRP-150 M	230	450	750	560	470	270	300	1000

BURNER	L2	Ø D1	Ø D4
GRP-250 M	295	270	300
GRP-280 M	307	300	330

TECHNICAL DATA

BURNER	GRP-130 M	GRP-140 M	GRP-150 M
Capacity oil, kg/h	34 - 132	50 - 180	60 - 240
oil, kW	390 - 1500	560 - 2040	680 - 2700
gas, kW	390 - 1500	410 - 2040	450 - 2700
Fan motor 3~ 400 V 50 Hz			
Output kW	3,0	4,0	5,5
Current A	6,2	8,7	11,1
Speed rpm	2880	2900	2910
Control unit	LFL1.322	LFL1.322	LFL1.322
Oil hose connection			
- suction	R½"	R½"	R½"
- return	R½"	R½"	R½"
Oil pump	TA2	TA2	TA2
- Motor 3~ 400 V 50 Hz			
Output kW	1,5	1,5	1,5
Current A	3,3	3,3	3,3
Speed rpm	2870	2870	2870
Preheater 3~ 400 V 50 Hz			
Capacity kW	6	6	12
Weight kg	167	174	198

BURNER	GRP-250 M	GRP-280 M
Capacity oil, kg/h	58 - 230	80 - 308
oil, kW	650 - 2600	900 - 3500
gas, kW	370 - 2600	500 - 3500
Fan motor 3~ 400 V 50 Hz		
Output kW	5,5	7,5
Current A	10,9	14,7
Speed rpm	2855	2855
Control unit	LFL1.322	LFL1.322
Oil hose connection		
- suction	R¾"	R¾"
- return	R½"	R½"
Oil pump	TA3	TA3
- Motor 3~ 400 V 50 Hz		
Output kW	1,5	1,5
Current A	3,3	3,3
Speed rpm	2870	2870
Preheater 3~ 400 V 50 Hz		
Capacity kW	12	12
Weight kg	233	238

Dual fuel burners, heavy fuel oil/gas

PI-diagram

GRP-130 M...-150 M, -250 M, -280 M

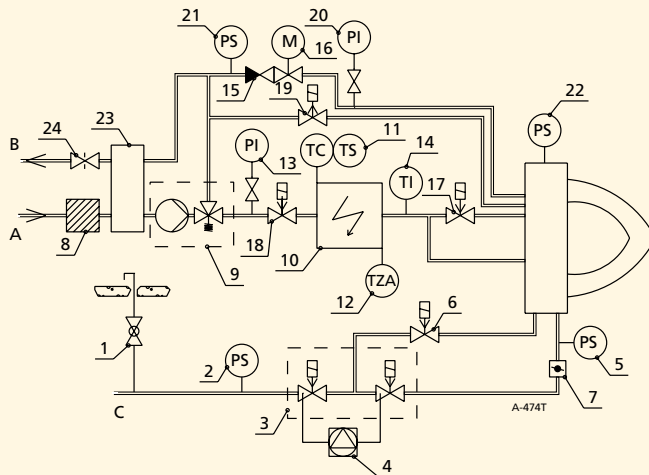

- 1 Ball valve, blow-off
- 2 Pressure switch, min.
- 3 Double solenoid valve
- 4 Valve leak tester
- 5 Pressure switch for gas, max.
- 6 Solenoid valve, NC, ignition gas *)
- 7 Gas butterfly valve
- 8 Oil filter
- 9 Oil pump, with plug
- 10 Preheater
- 11 Temperature regulation/lower limit
- 12 Limit thermostat
- 13 Pressure gauge, gauge valve
- 14 Thermometer
- 15 Non-return valve
- 16 Oil regulator/servomotor
- 17 Solenoid valve, NC
- 18 Solenoid valve, NC
- 19 Solenoid valve, NO
- 20 Pressure gauge, gauge valve
- 21 Pressure switch for oil, max.
- 22 Differential air pressure switch
- 23 Deaerator
- 24 Drilled ball valve

A Oil, inlet
 B Oil, return
 C Gas
 *) only on request

Capacity/back pressure graphs

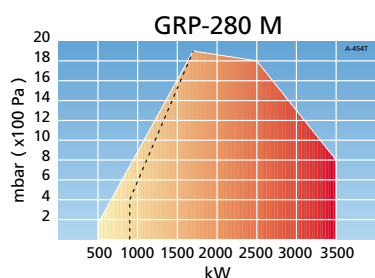
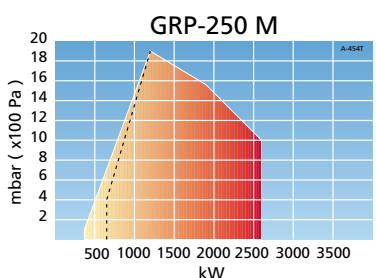
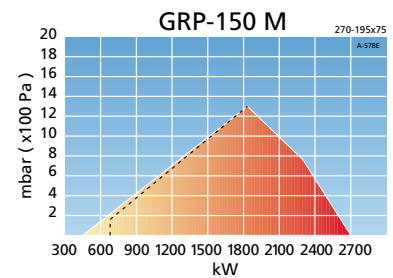
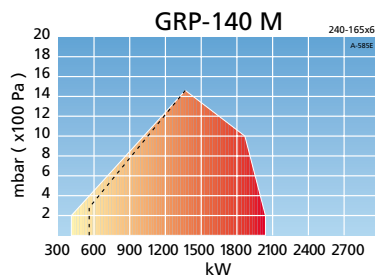
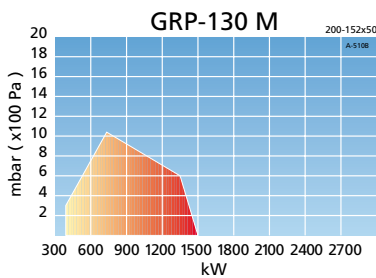

Natural gas: gases of 2nd family, groups H and E (equipment category I_{2R})
 Heavy fuel oil: 1 kg/h = 11.22 kW

Dual fuel burners, heavy fuel oil/gas

Scope of delivery

Burners include following equipment:

	GRP-130 M...-150 M	GRP-250 M, -280 M
Hinge flange with limit switch	•	•
Burner flange gasket	•	•
Oil nozzle/nozzles	•	•
Heating cartridge for oil nozzle	o	o
Solenoid valves for oil	•	•
Heating cartridge for solenoid valves	•	•
Oil pump with pressure regulating valve	•	•
Heating cartridge for oil pump	o	o
Separate motor for oil pump	•	•
Non-return valve	•	•
2 pressure gauges for oil	•	•
Thermometer	•	•
Pressure switch for return oil	•	•
Deaerator for oil	•	•
Electric preheater incl.: - limit thermostat - electronic temperature controller - temperature sensor	•	•
2 oil hoses, length 2000 mm	•	•
Electric tracing cables for burner oil pipes	o	o
Electric tracing cables for oil hoses	o	o
Oil filter	•	•
Pressure gauge for control of inlet oil	o	o
Pressure switch for control of inlet oil	o	o
Compound regulator for regulation of air/gas/oil ratio incl.: - oil regulator - servomotor	•	•
Potentiometer fitted in servomotor	o	o
Gas nozzle	•	•
Pressure gauge for measuring the pressure in gas nozzle	o	o
Gas butterfly valve	•	•
Gas pressure switch, max.	•	•
Differential air pressure switch	•	•
Ignition transformer	•	•
Ignition cables and electrodes	•	•
Flame sensor	•	•
Inbuilt combustion air fan with direct-driven electric motor	•	•
Air dampers	•	•
Pressure gauge for fan pressure	o	o
Control unit	•	•
Capacity controller	•	•
Motor contactors and thermal relays	•	•
Preheater contactors	•	•
Operating switches	•	•
Elbow 90°	•	•
Double solenoid valve incl.: - gas pressure switch, min. - 2 gas valves - automatic valve proving system - ball valve, blow-off (loose)	•	•
Solenoid valve for ignition gas		•
Manual	•	•

• standard delivery o option

Gas valve selection table

BURNER SERIES 130...150

BURNER	GAS VALVE		BURNER MAX. CAPACITY kW *)				COMBUSTION HEAD
			GAS INLET PRESSURE				
	SIZE	TYPE **)	20 mbar	30 mbar	50 mbar	100 mbar	
GKP-130 H	R2"	MB-ZRDLE	940	1150	1480	1500	200-152x50
GP/GKP/GRP-130 M	DN 50	DMV-DLE	990	1210	1500	1500	200-152x50
	DN 65	DMV-D	1140	1400	1500	1500	200-152x50
	DN 80	DMV-D	1230	1500	1500	1500	200-152x50
GP/GKP-140 H	R2"	MB-ZRDLE	1110	1360	1760	2350	240-165x60
GP/GKP/GRP-140 M	DN 50	DMV-DLE	1190	1460	1890	2350	240-165x60
	DN 65	DMV-D	1590	1950	2350	2350	240-165x60
	DN 80	DMV-D	1870	2290	2350	2350	240-165x60
GP/GKP-150 H	R2"	MB-ZRDLE	1120	1370	1770	2500	270-195x75
GP/GKP/GRP-150 M	DN 50	DMV-DLE	1240	1520	1970	2700	270-195x75
	DN 65	DMV-D	1610	1980	2520	2700	270-195x75
	DN 80	DMV-D	1910	2340	2700	2700	270-195x75

BURNER SERIES 250, 280

GP/GKP/GRP-250 M	DN 50	DMV-D	1200	1500	2000	2600	270-195x75
	DN 65	DMV-D	1800	2200	2600	2600	270-195x75
	DN 80	DMV-D	2300	2600	2600	2600	270-195x75
	DN 100	DMV-D	2600	2600	2600	2600	270-195x75
GP/GKP/GRP-280 M	DN 50	DMV-D	1300	1600	2100	3000	300-215x75
	DN 65	DMV-D	1900	2400	3100	3500	300-215x75
	DN 80	DMV-D	2700	3300	3500	3500	300-215x75
	DN 100	DMV-D	3200	3500	3500	3500	300-215x75
	DN 125	DMV-D	3500	3500	3500	3500	300-215x75

NOTE! If the gas inlet pressure is less than 20 mbar or if the gas used is not among those mentioned, evaluation must be made case-specifically.

*) The max. capacities shown in the table are achieved when the boiler back pressure is 0.

Natural gas 1 m³/h ≈ 10 kW

***) or corresponding type

Gas inlet pressure (Pmax) at burner

- max. 500 mbar when using DMV-D valve

- max. 360 mbar when using MB valve

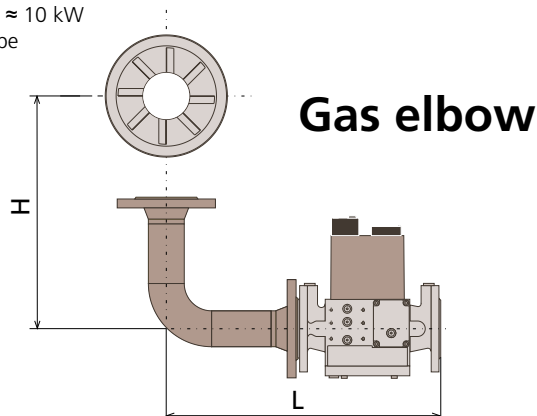

GAS ELBOW DIMENSIONS WITH DIFFERENT VALVES

		R2"	DN50	DN65	DN80	DN100	DN125
	H	L	L	L	L	L	L
GP/GKP/GRP-130...150	440	435	465	505	530	580	750
GP/GKP/GRP-250...280	450	-	510	560	615	665	745

Other dimensions available on special request

Burner preheater

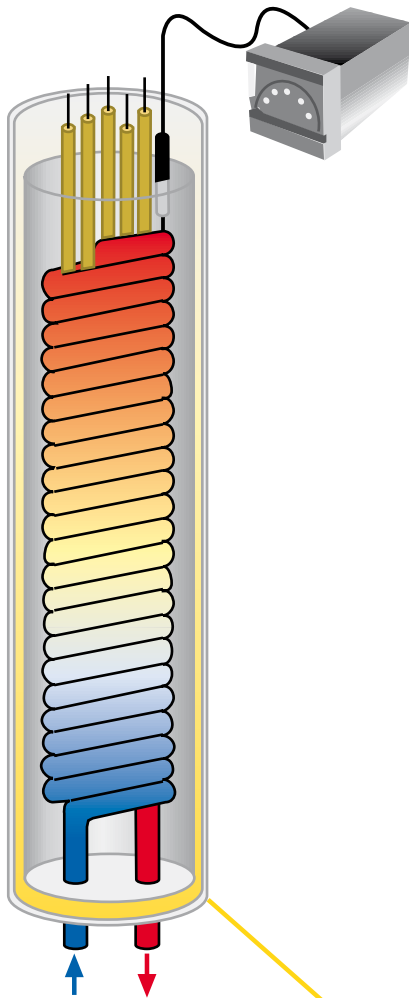

Accurate temperature control guarantees good combustion

In burning heavy fuel oil, the right atomising viscosity of the oil is essential for good combustion and low combustion gas emissions. A prerequisite for stable atomising viscosity is that the oil temperature stays stable throughout the firing rate.

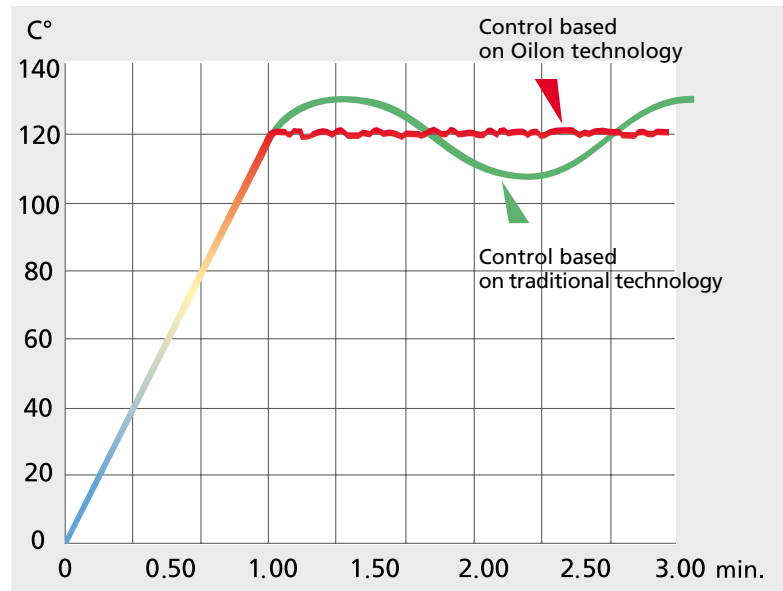

Oilon ML mass preheater keeps the oil temperature stable even if the incoming temperature fluctuates. On account of the construction and the electronic regulator, the temperature of the oil flowing to the nozzle remains stable. The burner may, depending on the capacity and model, have one or more 6-kW heater equipped with a safety device to guard against overheating. The electronic regulator has an integrated minimum temperature limiter as well; this prevents the burner from starting if the oil is too cold.



Silencer

Intake silencer

Construction

The silencer is made of steel plate lined with fireproof dampening wool. The silencer is connected to the burner's suction side via a screw connection. The silencer reduces the high-pitched sound produced by the air flow.



Silencer

Construction

The silencer is made of steel plate lined with fireproof dampening wool. This wheel-equipped silencer isolates the burner from four sides. Silencer reduces the sounds produced when the burner operates.



WiseDrive 32-34, an electronic regulator for controlling the fuel/air ratio

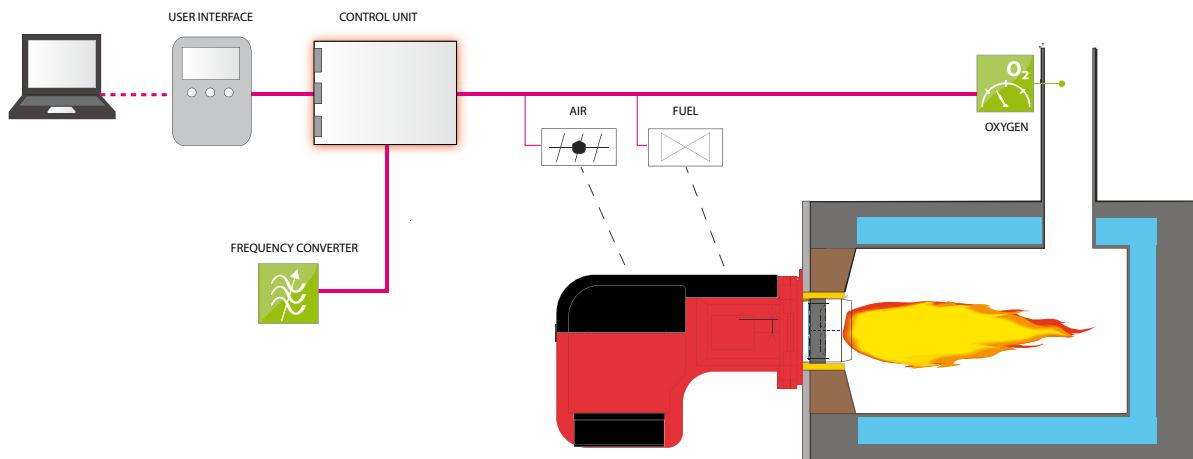

Low NOx technology for lower combustion gas emissions

The development of the Low NOx burners increased the Oilon burner selection considerably. The greatest improvement took place at the burner combustion head, where changes to the flow of the combustion gases enable lower NOx emissions. Various tests and practical experience prove that the Low NOx burners can achieve 40 to 60 % lower emission levels than traditional burners do. The carbon monoxide emissions of the Low NOx burners are also very low.

The high efficiency typical of Oilon burners applies to the Low NOx burners, too. With respect to the setting dimensions, the outer dimensions of the burner combustion head are the same as those of standard burners, so Low NOx burners are easy to install in place of traditional Oilon burners, without even electrical modifications. The burners are designed for gases of 2nd family, groups H and E.





Masonry figure

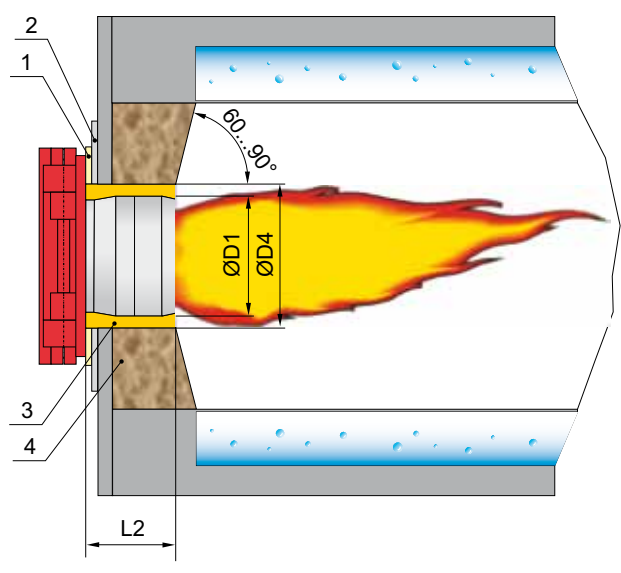

- 1 Gasket
- 2 Mounting panel
- 3 Ceramic wool or equivalent
- 4 Masonry
- ØD1, ØD4, L2 See burner dimension diagram

Flame dimensions

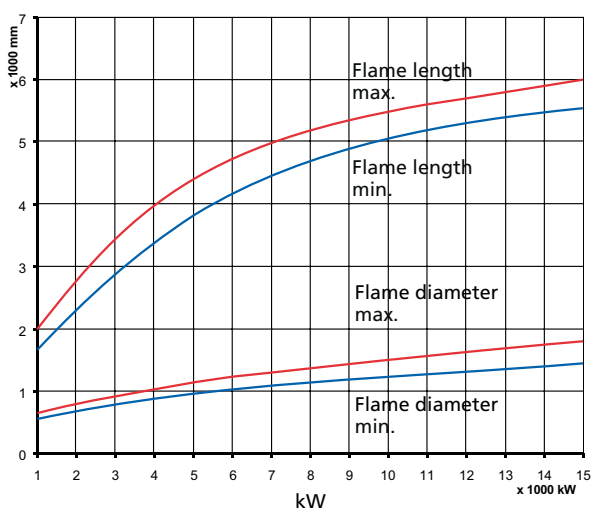

The dimensions apply for light oil and gas. For heavy oil, the dimensions used must be larger.

Servomotor



The new, advanced servomotor of the modulating burners makes it possible to determine the minimum capacity of the burner more quickly than before.



Oil supply diagram for heavy fuel oil

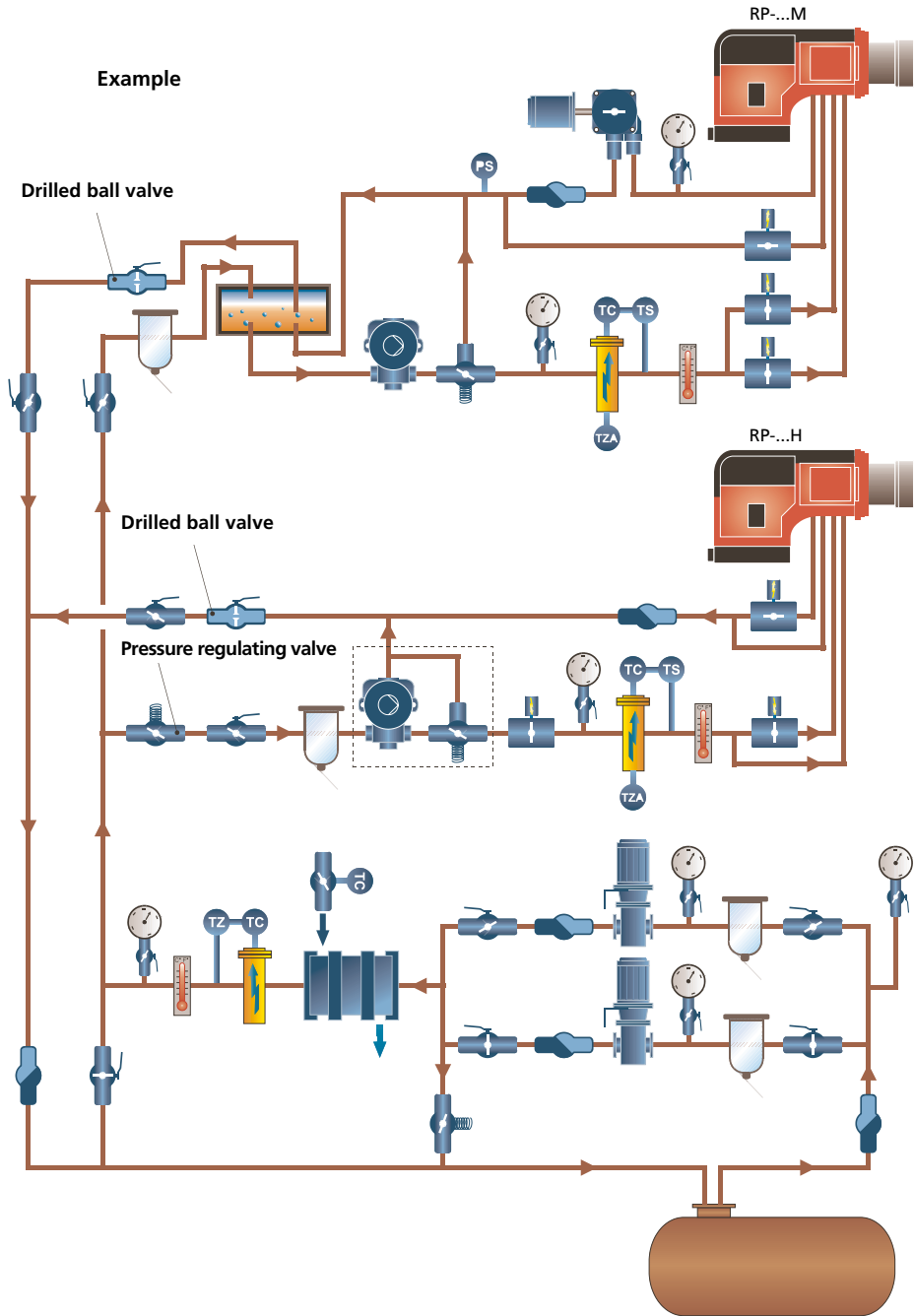

Gas pressure control assembly

Example





Oilon invests in product development and research. A modern product development centre meeting all European standards enables us to perform a wide range of burning tests and accurate oil and gas measurements.



We supply burners for ships according to classification societies, such as ABS, BV, CCS, DNV, GL, KR, LR, NKK, RINA, and RS classifications.



We participate in trade shows around the world every year.

OILON OY

Metsä-Pietilänkatu 1
P.O. Box 5
FI-15801 Lahti, Finland
Tel. +358 3 85 761
Fax +358 3 857 6239
info@oilon.com
www.oilon.com

